

National Quality Benchmark  
National Contract-abiding And Credit-worthy Enterprise  
High-tech Enterprises



To Create Value For Customer  
To Seek Benefit For Staff  
To Accumulate Wealth For Society.



## YUGONG CRANE

Web: [www.ygcrane.com](http://www.ygcrane.com) Email: [sales@ygcrane.com](mailto:sales@ygcrane.com)  
Tel: +86 13525095606  
Address: Changnao Industrial District, Xinxiang City, Henan Province, China.  
453000.



CRANE SPARES

# CATALOG

YUGONG CRANE

[www.ygcrane.com](http://www.ygcrane.com) Email: [sales@ygcrane.com](mailto:sales@ygcrane.com)



# CONTENTS

Company Profile .....	01
DRS Wheel Box .....	02
Crane Wheels .....	04
Sheaves .....	06
Crane Hook .....	08
Crane Rope Drum .....	09
Grab .....	10
Transfer Cart .....	11
Electromagnet .....	12
Other Kinds Of Spreaders .....	14

## Company Profile

YUGONG CRANE (Henan Dafang heavy machine Co., Ltd) was founded in 2007, it mainly deals in designing, researching, manufacturing, and selling bridge and gantry cranes, electric hoist, crane spares, steel structures and etc. YuGong Crane has been awarded "top 500 Chinese machinery enterprise", "contract credit enterprise in China", "famous product in Henan province", "High-tech enterprise in Henan province", "quality credit AAA industrial enterprises in Henan province" and etc.

We are located at Changyuan town, Henan province which has a good reputation of "the hometown of Crane in China", which covers an area of 850 thousand square meters with registered capital 230 million RMB, has a staff of more than 1600 people. Our company has powerful technical research strength, the independently developed multi-function crane, light duty series product(electric hoist, single girder/double girder overhead crane and gantry crane) and road & bridge handling equipment, and have been put into use in metallurgy, electricity, high-speed rail, machinery, mining, petrochemical industry and etc. we have a high reputation in home and abroad currently. The annual output of a Single girder (electrical suspension crane) has reached more than 25000 sets, a double girder crane of more than 1800 sets. Yugong-crane is a large crane manufacturing enterprise, which has the largest workshop area, different types of cranes, fast delivery and most economic products. We also have all kinds of advanced mechanical machining equipment and physical, electrical, hydraulic, chemical testing methods. Introduce and establish an international advanced management system, good sales network, and strong technical development power to be the world-class crane manufacturing enterprise to meet the needs of different market requirements.

Yugong Crane takes "for the customer, for employee, for society" as the core values to provide professional and efficient service for customers, to build stable and win-win relationships with customers, to create a comfortable working environment, good study environment, reasonable payment, and good development space for employee, to provide more employment opportunity for society, to make more tax income for the country, to build a conservation-minded, civilized, harmonious society.



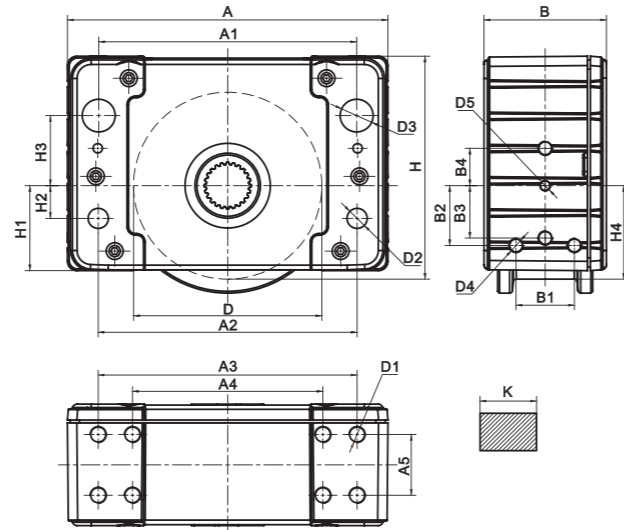

### • Technical Parameters

Type D	A mm	B mm	H mm	K mm	H1 mm	H2 mm	H3 mm	H4 mm	B1 mm	B2 mm	B3 mm	B4 mm
DRS112	190	96	131	55	47	30	40	80	40	30	-	24
DRS125	220	98	147.5	55	53.5	20	40	100	50	37	-	37.5
DRS160	275	110	187	60	70	25	55	100	54	47.5	-	20
DRS200	340	130	238	60	90	35	75	100	62	64	56	40
DRS250	385	150	281	75	89	50	80	100	-	-	-	-
DRS315	470	180	349.5	90	114	70	80	100	-	-	-	30
DRS400	580	210	440	-	144	95	130	100	-	-	-	30
DRS500	700	240	566	-	183	110	160	100	-	-	-	30

  

Type D	A1 mm	A2 mm	A3 mm	A4 mm	A5 mm	D1	D2 mm	D3 mm	D4	D5	Weight kG	Max.Load kN
DRS112	145	145	145	-	45	4xM12	10.5	18.5	4xM12	2xM12	10	27.5
DRS125	175	175	170	-	55	4xM12	13	21	4xM12	2xM12	15	50
DRS160	220	220	220	-	55	4xM16	17	30	4xM16	2xM12	26	70
DRS200	275	275	275	-	65	4xM16	20	35	8xM16	2xM12	41	100
DRS250	310	310	290	140	80	8xM16	34F8	40	2xM12	-	70	160
DRS315	370	370	360	180	100	8xM16	40F8	50	2xM12	2xM20	130	220
DRS400	450	450	440	210	120	8xM20	31H13	65	2xM12	2xM20	220	300
DRS500	580	580	620	480	125	8xM20	31H13	70	2xM12	2xM20	380	400

### • Installation Type

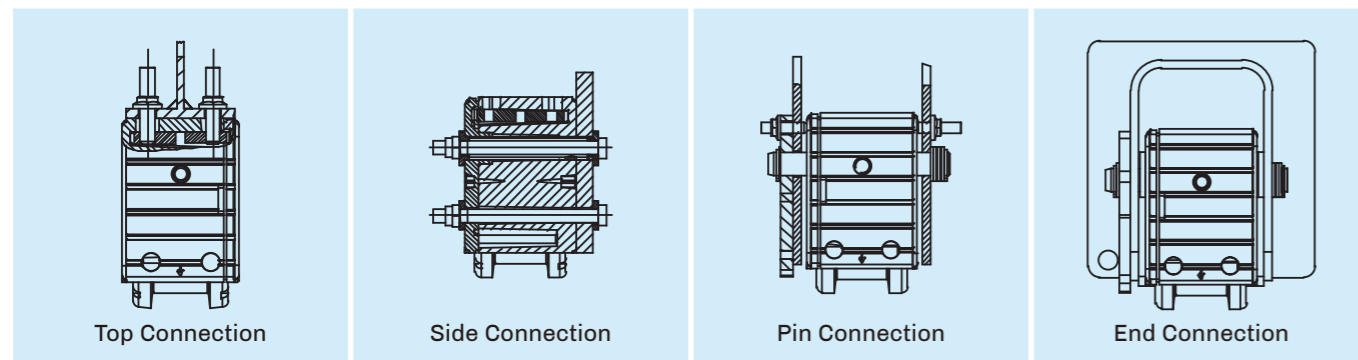

### • Motor Installation

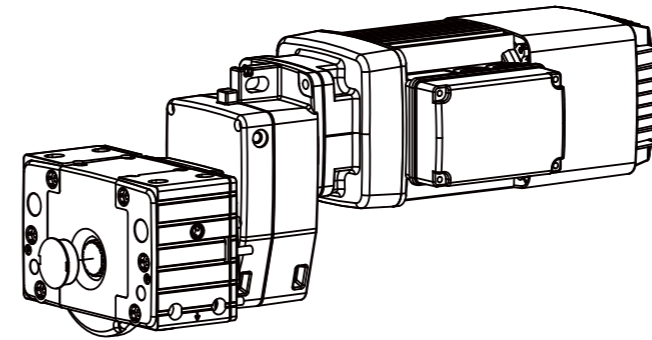

Offset Geared Drive

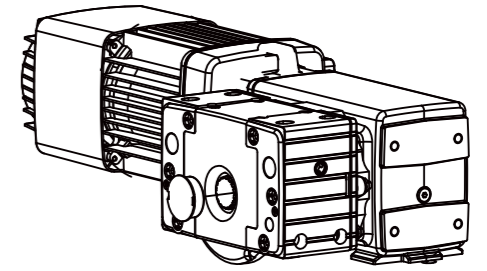

Angular Geared Drive

### • Accessories

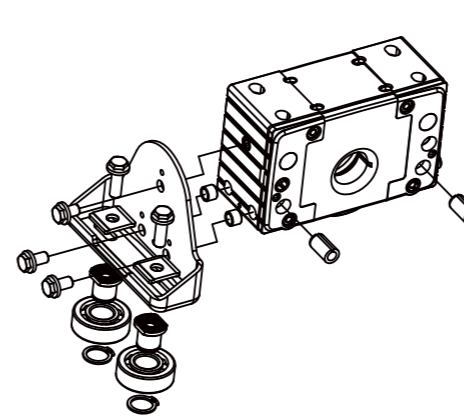

DRS112-200 Horizontal Guide Rollers

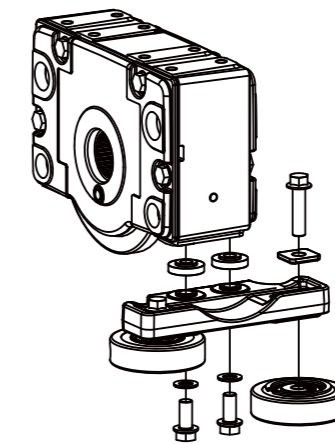

DRS250-500 Horizontal Guide Rollers

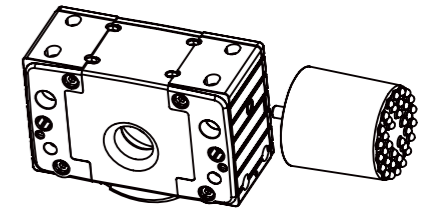

Buffer

### • Application Case







Crane wheels are replaced because of flange wear, flange breakage, and mechanical overloads characterized by pitting and spalling. Each of these inservice factors must be carefully considered before the combination of wheel design, material selection, hardness pattern and heat treating technology is selected.

That's why every hardened steel crane wheel is specially designed and heat treated to maximize its resistance to the damaging forces at work in heavy industrial applications.

## ● Processing

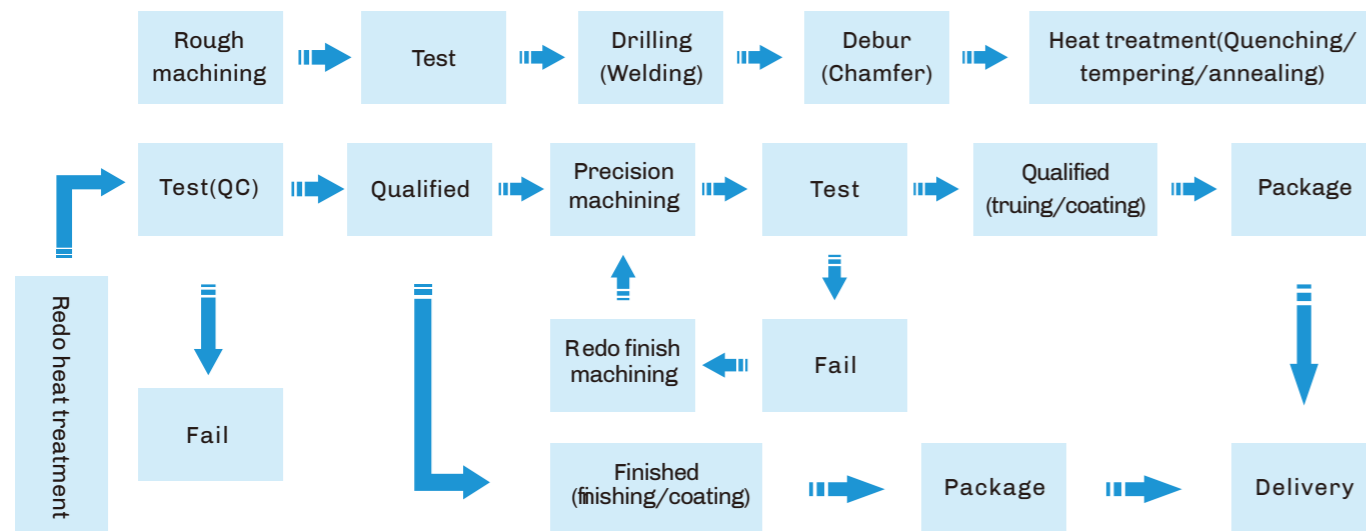

## ● DAFANG Crane Wheels are

- ▶ Manufactured from fine grain, fully killed, vacuum degassed forged medium carbon steel
- ▶ Heat treated using our in house processes to provide a uniform contour hardness in the tread and inner flange wear surfaces, while maintaining a ductile core to resist shock loads
- ▶ Resistant to flange fracture or wear
- ▶ Designed to resist pitting and spalling

## ● Applications

- ▶ Overhead cranes
- ▶ Transfer cars
- ▶ Gantry and portal cranes
- ▶ Etc

## ● Wheel Requirements

- ▶ The elements of the wheel are: material, dimensions, requirements, heat treatment,
- ▶ Material: 45, 55, 65, 50SiMn, 65Mn, 42CrMo, SSW-Q1R, ASTM A504, etc., cast or forged
- ▶ Size: The processing capacity is 150-1250 in diameter, and the tread size is generally used as the naming size of the wheel
- ▶ Requirements: Dimensional tolerances, hardness, defect detection (NDT), mechanical properties.







A pulley sheave has many specifications that can be customized for a particular job. Based on these factors, it can be used in a variety of industries. Users must consider how frequently the sheaves will be used, as well as what the weight load will be.

Sheave height and width also are considerations that directly influence performance, because smaller wheels operate faster but usually cannot carry the same load. The pulling radius, cable diameter and maximum tension for the cable are other considerations that go into choosing the perfect sheave for a job.

Sheaves material: Cast, Forged, Forged Welded, Nylon.

## ● Cast Sheaves

Casting Sheaves are made into blanks through the casting process, and then machined into finished pulleys. Since the lost foam casting method is adopted, the production cost is low and the efficiency is high. For some pulley products with large size, non-standard shape and complex process, casting is an ideal production method.



## ● Forged Sheaves

Forged sheaves are generally made by free forging, which is integrally processed after forging, and then made by subsequent processing procedures such as heat treatment. Its performance is good and the quality is high, but the production cost is high, and it is generally used in places that are not conducive to maintenance and repair, such as port machinery, ships operating at sea, and oil drilling platforms.



## ● Forged Welding Sheaves

Forged Welded sheaves have a special form and complex manufacturing process, and are generally used in port machinery. The forging and welding pulley is firstly forged to form the part of the pulley rope groove, and then the pulley web and hub are welded after fabrication, and finally processed into a finished product. The same performance as forged pulleys can be achieved, and the overall cost is lower than forged pulleys and higher than rolled pulleys.



## ● Nylon Sheaves

The nylon sheave is made of MC nylon casting and is processed into a finished product by a machine tool. Nylon pulley has the characteristics of light weight, low noise, good mechanical properties, high strength, good toughness, impact resistance and fatigue resistance. Mainly used for engineering truck cranes, crawler cranes, tower cranes, bridge erection machines, coal unloads, port machinery, elevators and other large-scale lifting machinery and equipment.







# Crane Hook



Crane hook is a device for grabbing and lifting loads by means of a device such as a hoist or crane.

Hooks can be classified into single hook and double hooks according to the appearance; forged hooks and strapped hooks according to production method.

We can supply single hook, double hook, Strapped hooks, and hook assembly as your request. There are some standard technical data for your reference.

Note: Hook is usually equipped with a safety latch to prevent the disengagement of the lifting wire rope sling, chain or rope to which the load is attached.

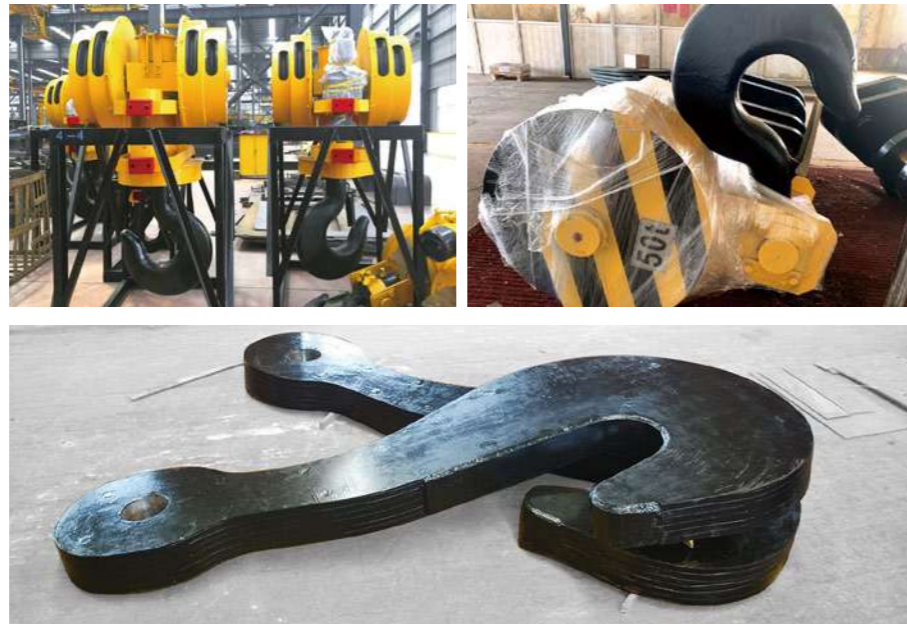

# Crane Rope Drum



- ▶ Material: Q235, Q345, 45#
- ▶ Heat treatment: Hardening and tempering, high frequency quenching, carburizing quenching and so on
- ▶ Groove surface quench: HRC45-55
- ▶ Groove surface quench depth: ≥2mm
- ▶ Max processing diameter: 2,000mm
- ▶ Inspection: All items are checked and tested thoroughly during every working procedure and after the product is finally manufactured to ensure that best quality product goes out in the market.







# Grab



Grab bucket are designed as per, volume of material to be lifted and its cycle time of delivering the raw material to other line.

Grab buckets are required in the cement, sugar industry and various other industries for the applications and handing of bulk raw material to feed the supplies.

## ● Application Case



# Transfer Cart



The transfer cart is designed for transporting heavy cargoes or equipment from one bay to another in factory. It can be used indoor or outdoor. The fields include metallurgy, foundry, new factory construction and shipbuilding and so on.

With different styles and standard capacities up to 300 tons, we have the solution you need and each style can be designed for your specific application.

- ▶ Steel Ladle Transfer Car
- ▶ Turning rail transfer carts
- ▶ Tinplate rail transfer cart
- ▶ Vacuum furnace using ferry transfer cart







## ● Application

- ▶ It is used for lifting and transporting magnetic conductive materials such as steel in metallurgy, mining, machinery, transportation and other industries.
- ▶ It is used as an electromagnetic manipulator to hold magnetic conductive materials such as steel.

## ● Main Features

- ▶ It adopts fully sealed structure and has good moisture-proof performance;
- ▶ The computer-optimized design has reasonable structure, light weight, large suction and low energy consumption;
- ▶ The excitation coil is treated by a special process, which improves the electrical and mechanical properties of the coil, and the heat resistance of the insulating material has reached the C level, and the service life is long;
- ▶ The rate Power-on duration rate of ordinary electromagnets has been increased from 50% in the past to 60%, which improves the use efficiency of electromagnets;
- ▶ The ultra-high temperature lifting electromagnet adopts a unique heat insulation method, and the temperature of the absorbed material is increased from 600C in the past to 700C, which expands the scope of application of the electromagnet;
- ▶ The constant voltage control mode is usually adopted, and the strong excitation control mode (DC-290V/DC--220V) and the constant current power supply mode can also be used. It can not only improve the lifting capacity, but also save energy and improve economic benefits;
- ▶ Easy installation, operation and maintenance.

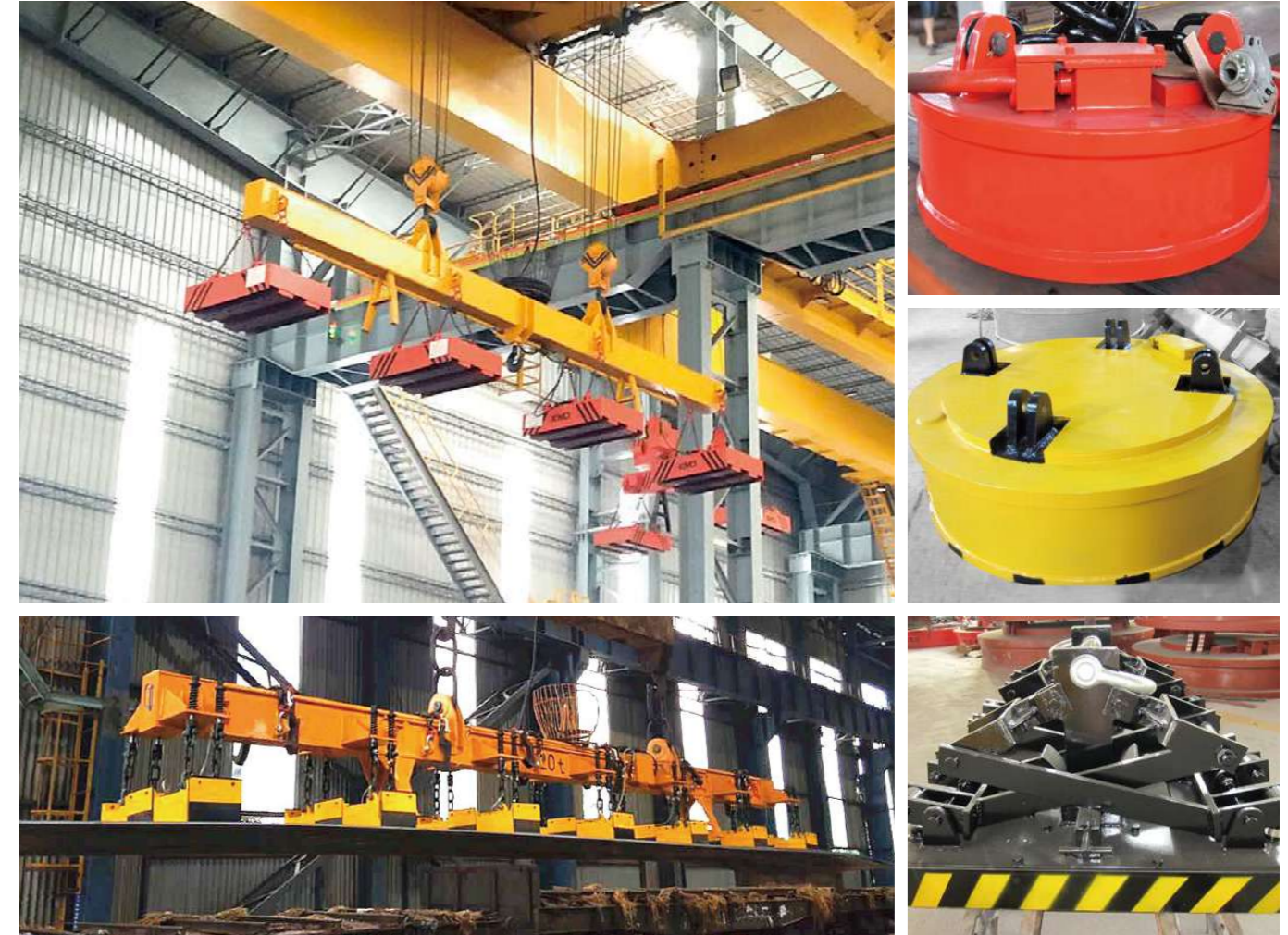

## ● Notes on Model Selection

- ▶ When the temperature of the suction and transport materials is lower than 100C, please use the normal temperature type lifting electromagnet; if the temperature exceeds 100C, please use the high temperature type lifting electromagnet. If the temperature exceeds 600C, please use an ultra-high temperature lifting electromagnet.
- ▶ When the power-on duration exceeds 60%, please use a high-frequency lifting electromagnet.
- ▶ When sucking and lifting materials in water, please choose the diving type (the diving depth is not more than 100m). The parameters of the submersible lifting electromagnet are the same as those of the normal temperature type. If users need diving type, please specify when ordering.
- ▶ Ambient temperature: normal temperature type - -5C~40C, high temperature type -5C~50C. The altitude does not exceed 2000m.
- ▶ Equipment matching: when a single unit is used, select the rectifier control equipment and auxiliary equipment according to the power consumption (current); when multiple units are used in combination, select according to the sum of the power consumption (current) of the number of units used in combination.



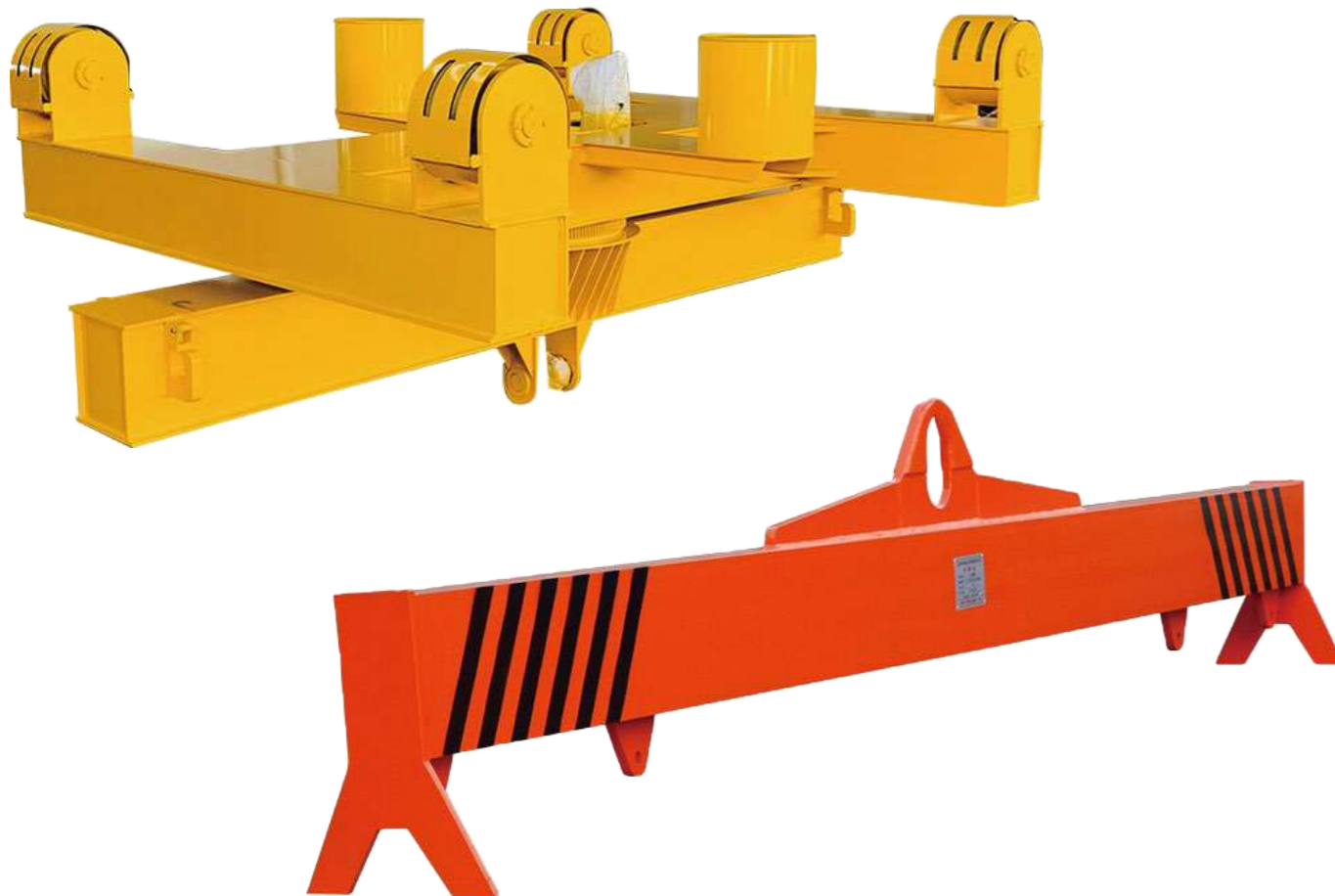
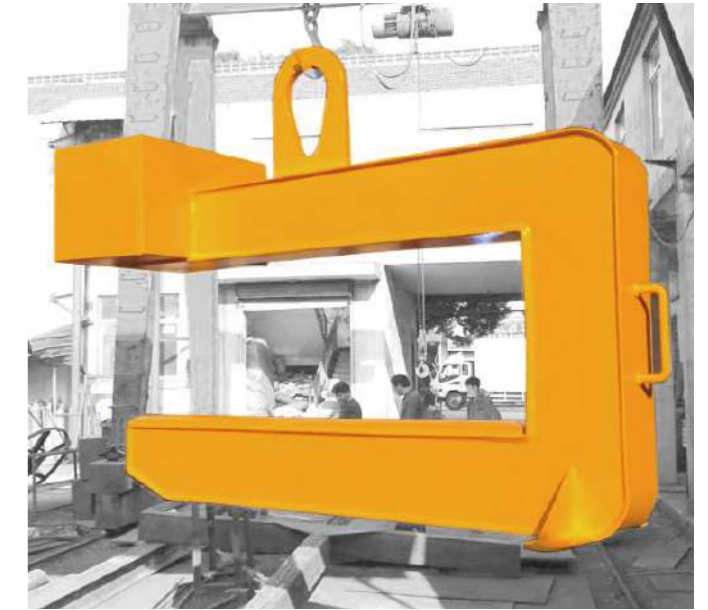

There are some special spreaders in lifting materials in kinds of industries, we can customized as your requirement.