电动双梁桥式起重机安装指导维修说明书

Double Girder Overhead Crane Operation Manual

豫工

YUGONG

目录

-
- 一、概述
 - (一) 结构形式
 - (二) 保证使用期限
 - 二、安装与调整
 - (一) 注意事项
 - (二) 起重机安装
 - 1. 小车
 - 2. 起重机金属结构
 - 3. 大车运行机构
 - 三、电气控制原理和安装
 - (一) 电气控制原理
 - (二) 电气设备的安装与调整
 - 四、架设
 - (一) 注意事项
 - (二) 架设实例
 - 五、起重机使用须知
 - (一) 安全技术规则
 - (二) 司机职责
 - 六、维护与故障处理
 - (一) 桥架与其主要构件
 - (二) 大，小车运行机构
 - (三) 起升机构
 - (四) 抓斗机构维护和保养
 - (五) 电磁起重机点磁盘维护
 - (六) 电气设备
 - 1. 电气检修制度
 - 2. 故障处理
 - 七、机构的润滑
 - (一) 起重设备各润滑点的分布
 - (二) 润滑条件与润滑材料
 - 八、运转试验
 - (一) 试车前的准备和检查
 - (二) 无负荷试车
 - (三) 负荷试车
 - 1. 负荷试车的检验内容
 - 2. 静负荷试车
 - 3. 动负荷试车
 - (四) 电磁起重机的试车
 - (五) 抓斗起重机的试车
 - (六) 电气部件试验规定与检查项目
 - 九、起重机的交工验收
 - 十、附录
 - (一) 大车跨度测量法
 - (二) 主梁上拱度测量法

1. Brief introduction

- (1). Structural style
- (2). Guaranteed using time

2. Installation and adjustment of the crane

- (1). Matters need attention
- (2). Crane installation
 - a. Trolley

- b. Crane metal structure

- c. Crane traveling mechanism

3. Electric control principle and installation

- (1). Electric control principle
- (2). Electrical device installation and adjustment

4. Hoisting construction

- (1). Matters need attention
- (2). Hoisting construction example

5. Crane using instructions

- (1). Safety technical regulations
- (2). Driver responsibilities

6. Maintenance and fault handling

- (1). Crane structure and main component
- (2). Crane traveling mechanism and trolley traveling mechanism
- (3). Lifting mechanism
- (4). Grab mechanism maintenance
- (5). Electromagnetic crane magnet disc maintenance
- (6). Electrical device
 - a. Electrical maintenance system
 - b. Fault handling

7. Mechanism lubrication

- (1). All lubricating points distribution of lifting equipment
- (2). Lubrication condition and lubrication material

8. Running test

- (1). Prepare and checking before running test
- (2). Non-loading commissioning
- (3). Loading commissioning
 - a. Loading commissioning inspection contents
 - b. Static loading commissioning
 - c. Dynamic loading commissioning
- (4). Electromagnetic crane test run
- (5). Grab crane test run
- (6). Test regulations and inspection items of electrical part

9. Crane project checking and accepting

10. Appendix

- (1). Crane span measurement
- (2). Main beam upper deflection measurement

5-125/30 吨电动吊钩桥式起重机适用于工矿企业内部或露天场地。在固定跨间内装卸，运搬物料和物品。

5-125/30t Electric hook overhead crane is applied to the internal or open places of the industrial and mining enterprises. Used to load and unload, and transport material in the fixed straddle.

起重机采用 415 伏 50 赫兹，三相四线制。主要性能参数可参阅起重机的附加图中总图所载有关数据。本说明书用于起重机的安装、架设、交工、验收、使用和维修。

Crane applies 415V 50HZ three-phase four-wire system. Please refer the related data shown in the additional crane general drawing for main technical parameters. This introduction is used for the installation, erection, handing over, acceptance, usage and maintenance.

(一) 结构形式/ Structure form

5-125/30 吨电动桥式起重机（请参阅起重机附加图）主要由桥架、大车运行结构和装有起升、运行机构的小车组成。其桥架由钢板焊成的正轨箱形主梁、端梁和走台等组成。主梁上铺设了供小车运行的钢轨。两主梁的外侧装有走台。一侧为安装及检修大车运行机构而设。另一侧为安装小车导电装置而设。在主梁下面悬挂着全视野的操纵室，操纵室内装有联动控制台或单个控制器，操纵室与走台装有斜梯。主梁连接在中间带有接头的两端梁上。

5-125/30t Electric overhead crane (please refer to the additional drawing of crane) mainly consists of bridge frame, crane traveling mechanism, trolley with lifting and traveling mechanism. The bridge frame is composed of steel plate weld center rail box type main beam, end carriages and platform, etc. The rail for trolley traveling is laid on the main beam. The platform is installed on outside of the two main beams. One side of platform is for the installation and maintenance of crane traveling mechanism, another side is for the installation of trolley conductive device. There is the full-filled cabin room hanging under the main beam, which installed the linkage console or a single controller. The inclined ladder is fixed between the cabin room and platform. The main beam is connected with the end carriages with the joint in the center.

大车运行机构采用分别驱动形式（图 1-1）。起重机大车车轮为四个或八个车轮与带有滚动轴承的角形轴承箱组装以后安装在端梁的两端。

The crane traveling mechanism applies the separate drive form (Picture 1-1). The crane wheels has 4 or 8 pieces, which are assembled with angle type bearing box with rolling bearings, and then are installed on two sides of end carriages.

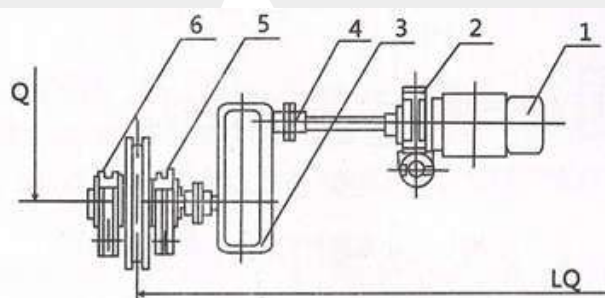

Picture1-1 Crane separate drive mechanism sketch

图1-1 大车分别驱动机构简图

1. 电动机；2. 制动器；3. 减速器；4. 联轴器；5. 大车车轮；6. 角型轴承箱
1.Motor; 2.Brake; 3.Reducer; 4.Coupling; 5.Crane wheel; 6.Angle type bearing box;

起重机的小车有起升机构（图 1-2）和小车运行机构（图 1-3）所组成。起升机构有双保护（装有两套起升安全开关装置）和单保护两种，可供用户选择。

The crane trolley is composed of lifting mechanism (Picture 1-2) and trolley traveling mechanism (Picture 1-3). The lifting mechanism has two types, double protection (equipped with two sets of lifting safety switch device) and single protection, which can be chosen by the user.

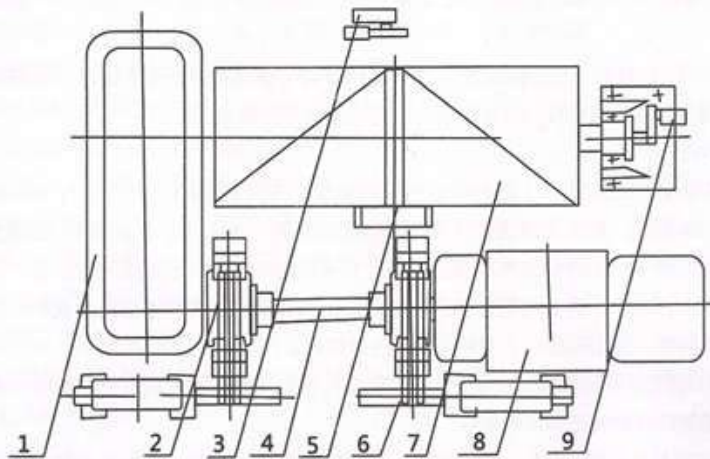

Picture1-2 Trolley lifting mechanism

图1-2 小车起升机构

1、减速器；2、制动轮；3、重锤起升安全开关；4、传动轴；5、定滑轮

6、制动器；7、卷筒组；8、电动机；9、旋转起升安全开关

1.Reducer;2.Brake wheel;3.Hammer lifting safety switch;4.drive shaft;5.Fixed pulley;6.Brake;7.Drum group;8.Motor;9.Rotate lifting safety switch



图1-3 小车运行机构

Picture1-3 Trolley traveling mechanism

1、电动机；2、制动器；3、车轮 4、角形轴承箱 5、联轴器 6、传动轴 7、减速器

1.Motor;2.Brake;3.Wheel;4.Angle type bearing box;5.Coupling;6.Drive shaft;7.Reducer

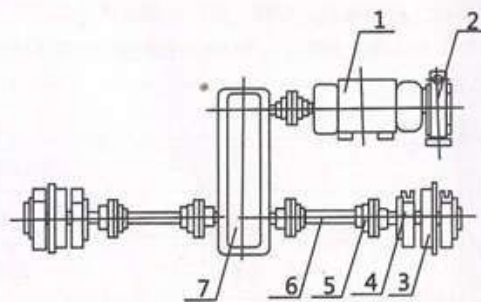
小车的供电有悬挂式电缆导电（电缆滑车所使用的轨道为异型内卷边槽钢）和圆钢、角钢导电两种形式，可供用户选择。根据用户要求大车导电处可设有导电维修平台。根据用户要求在操作室内附设的电热器、冷风机、空调的使用请参阅配套厂的使用说明书。

The trolley power supply has two types, hanging type cable conduction (the rail of cable pulley is abnormal shape inward flange channel) and round steel, angle iron conduction, which can be chosen by user. The conductive maintenance platform can be installed at the place of crane conductive place based on the user's requirements. About the usage of electric heater, air-cooler, air-condition equipped based on the user's requirements, please refer to the production factory operation instruction.

（二）保证使用期限 / Guaranteed using life

起重机到用户后，桥架及零部件必须妥善保管。凡本公司生产的起重机应按说明书的有关规定进行安

装，安装前要按规程验算厂房轨道。

The user should keep the bridge and spare parts properly after getting the crane. All cranes manufactured by us should be installed according to the related regulations in the instruction manual, and should be checked and calculated workshop orbit according to the regulations before installation.

自起重机发货后的十八个月以内，在起重机的安装、操作、使用符合本说明书的前提下，本公司将保证起重机正常工作十二个月（自使用之日起），电气部分零部件的保证使用期限按电气设备制造公司的规定。

Within the 18months after the crane delivery, under the condition of that the crane installation, operation, and usage confirm with the introduction manual, our company will guarantee that the crane can be working normally for 12 month(from the date of using), the operating life of the electrical parts should be based on the rules of electrical devices manufacturing company.

二、安装与调整/Second: Installation and adjustment

(一) 注意事项/Attentions

1、起重机到站卸车搬运，应特别注意避免发生起重机受到扭、弯、撞坍等事故。为此，必须遵守下列规定：

When the crane arrives at station, and to be unloaded and transported, should pay attention to avoid the accidents such as torsion, bending, hitting slump, etc. So, you must obey the following rules:

① 起吊时至少须有两个吊点，吊点的捆扎处须有衬垫物，捆扎以走轮或主梁本身为限，并尽可能选在桥架的两端即主梁与端梁的连接处

Two lifting points are needed at least during the hoisting, and there should be backing in the strapping place of lifting point, and the strapping should be limited by the moving wheels or main beam, and should be chosen at the two ends of the bridge frame (that is the connection of main beam and end carriages) as much as possible.

② 如无载重汽车等设备搬运时，应将桥架、端梁等搁置于平车上拖动，禁止在地面或架滚上拖动。

If there are no heavy trucks and other devices for transporting, should put the bridge, end carriages, etc. on the transfer car, and it's forbidden to drag them on ground or rolling frame.

2、存放时应安置平稳，并用枕木放平垫实。枕木要对称放置，地面应坚实，不得日久下沉，致使桥架发生变形。

When storing, should be laid steadily, and lay the sleeper properly. The sleepers need to be laid in symmetry, and the ground should be firm. And the sleepers cannot be sunk after long time, and cannot make the bridge frame out of shape.

3、如起重机在较长时期内放置，应妥加防晒、防风、防雨、防腐蚀等措施。

If the crane will be put aside for long time, should do the proper sun proof, wind proof, rain proof and corrosion proof, etc. measurements.

4、安装前应组织有关人员认真研究图纸根据技术要求消除由于运输不当或保管不妥所产生的变形和缺陷。特别对金属结构部分的变形，需在校正后才能安装。

Before installation, should organize the related people to study the drawings, and should remove the deformation and defects owing to the improper transportation or storage based on the technical requirements. Especially for the deformation of the metal structure part, should do the correction at first, and then do the installation.

5、起重机到货后，应根据装箱单清点零部件，并将结果记录在“设备档案卡”上（由用户自备）。

After the crane arrived factory, should check the spare parts based on the packing list, and record the results on the “Device File Card” (prepared by user).

6、对分部（非完整总装）到货的设备，应在地面进行予装，经予装测量符合图纸及有关要求后再整体或部分架设。在予装时必须按起重机安装连接部位标号图进行。发现产品存在用户解决不了的

问题，请立即与制造厂联系，否则该起重机架设到厂房上后，将无法处理这类问题。

If just the some parts of device (not complete assembly) arrived factory, should do the preassembly at the ground at first, and then if meet the drawing and related requirements measurements, then can do the overall or part installation. And you must preinstall all the parts based on the crane installation parts labeled graph. If the product has some problems which the user cannot deal with, please contact the manufacturer directly, or if the crane already been installed in the workshop, then this kind of problems cannot be handled.

7、对存放日期较长的（一般超过十二个月者）特别是露天置放的设备，安装前应检查锈蚀情况，清楚污渍，必要时重新涂油组装，润滑油管必须洗内壁，重新打油，使各转动部分灵活转动，还需检查各连接部分是否牢固、可靠。

For the devices which stored for much long time (exceed 12 months in general), especially for the ones put in the open air place, should check the rusting condition, and clear the stains before installation. If necessary, do the fat liquoring and assembly again, and the lubricating pipe inner wall must be cleaned, and be oiled again, to make all rotating parts rotate flexibly. And also need to check all connection parts are fixed and reliable or not.

8、安装所用的测量工具必须具有标准部门近期内的鉴定。

The measurement instruments used for installation must get the identification from standard department in the near future.

(二) 起重机安装/Crane installation

1、小车/Trolley

小车在制造厂均经试车检验合格。因此，在稍经调整消除运输变形后就可以直接安在桥架上。在桥架安装符合有关技术条件的情况下，小车不得存有三条腿的情况（即小车轮只有三个与轨道接触，另一个悬空）。否则，要在悬空车轮的轴承箱下或者轨道下进行加垫调整。垫只能是一层，轨道下加垫时必须置于主梁筋板处，两 endpoint 焊固定。

Trolley all pass the commissioning inspection at the manufacturing factory. Hence, it can be installed on the bridge frame directly after slightly adjustment to eliminate transportation deformation. Under the circumstances that the bridge frames' installation confirm with the related technical conditions, the three legs situation cannot be existed (Which means that there are just 3 wheels touching the rail, and the last one is hanging in the air). Or else, should lay the pads to do the adjustment under the bearing box of hanging wheel or under the rails.

The pad can only be one layer, the pad under rail must be laid at the reinforcing plate of main beam, and two ends should be fixed by spot welding.

2、起重机金属结构/Crane metal structure

① 金属结构的各项检测指标按表 2-1 规定执行，为减少高空作业量，各设备的安装，接线等尽可能在地面进行。

Each detected index of metal structure should be executed according to the rules of Table 2-1. In order to reduce the high altitude workload, all devices' installation, and wiring, etc. should be proceed on the ground as much as possible.

② 起重机在架设前须按下述方法进行予装，如发现弊病及时消除，如用户无法处理请立即与制造厂联系，当起重机架设上厂房以后，制造厂也无法处理这类问题。

Before installing the crane, should preassemble it according to the following methods. If find problems, should solve it in time, and if the user cannot deal with these problems, please contact the manufacturing factory at once. If the crane already been installed in the workshop, then the manufacturers cannot handle these kinds of problems either.

a. 将起重机放在两根平行且处于同一平面的道轨上。

- a. Put the crane on two parallel rails that be on the same plane
- b. 以端梁螺栓孔为定位基准，按照附加图——起重机安装连接部位标号连接端梁，将起重机组合起来，调整合适后便拧紧螺栓。起重机组装完毕后，各项指标均应符合附加图有关规定与附表 2-1 有关数据。
- b. Regarding the bolt-hole on the end beam as the benchmark and connect the end beam according to the installation mark number on the additional charts. After assembling and adjusting the crane, tight all the bolts. After finishing the installation, all the indicator should satisfy the related rules on the additional charts and the related data on the attached sheet 2-1.

3. 大车运行机构/ Crane traveling mechanism

大车运行机构已由制造厂组装在桥架上，试验运转合格后随桥架一起发运。大车运行机构在起重机组装完后，应根据下列条件进行安装检查：

The crane traveling mechanism has been installed on the steel structure by the manufacturer and shipped along with the bridge after passing the test run. Once the crane traveling mechanism be finished, it should be checked according to the following conditions:

①起重机的跨度差不大于 $\pm 5\text{mm}$,且两侧跨度 L_1 和 L_2 的相对差不大于 5mm 跨度的测量点按图 2-1, 测量跨度采用的拉力值和修正值见附录 (一)。

① Deviation of crane span cannot be over $\pm 5\text{mm}$ and the relative of L_1 and L_2 cannot be over 5mm . The measuring point of span should be according to 2-1, and the KN and corrected value of span should reference appendix (一)



图 2-1

(测量点: Measuring point)

②车轮的垂直倾斜 $a \leq L/400$, L 为测量长度, 且上边应偏向轨道外侧, 在桥架搁置于端梁, 车轮架空的情况下测量 (见图 2-2)。

② Hade of wheel $a \leq L/400$, L is the measuring length and the top should be biased towards lateral track. The measure should under the situation: the steel structure put on the end beam and the wheels are Elevated status.

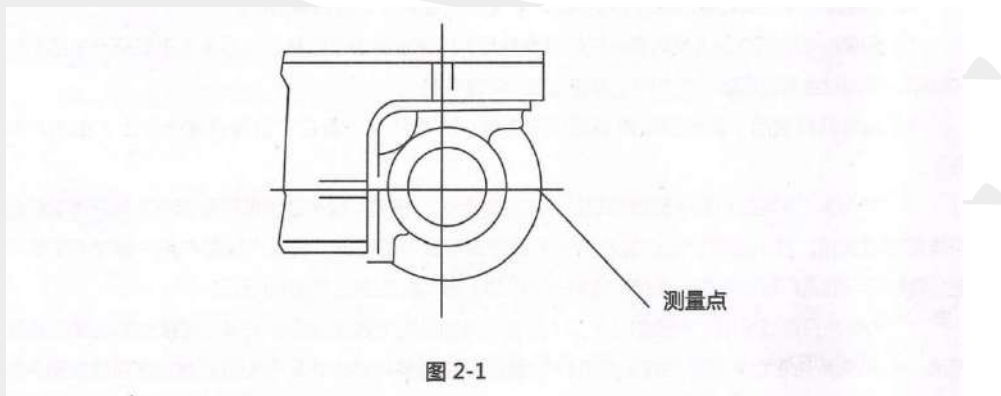

图2-2

(A 向: A direction)

③车轮的水平偏斜 $p \leq L/1000$, L 为测量长度, 且同一轴线一对车轮的偏斜方向相反 (见图 2-3)

③ Lateral deviation of wheel $p \leq L/1000$, L is the measuring length and the direction of deflection of each pair

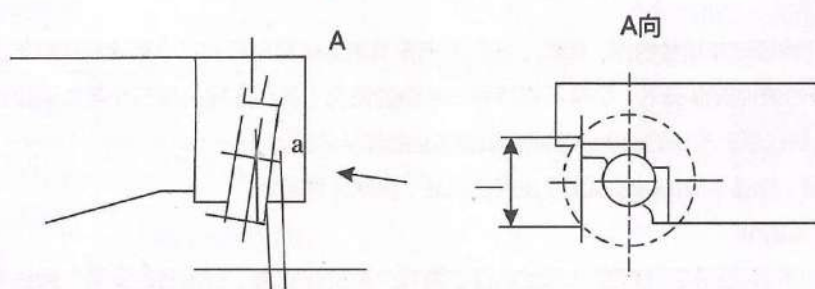
wheel on the same axis are opposite direction (reference 2-3)



图 2-3

(A 向: A direction; 轮距: wheel-base; 跨度 (轨距): span (gauge))

④传动轴中心的摆幅 <1 毫米: 对于大于 1 米的低速级传动轴 $<L/1000$ (L 为转动轴长度)。

④Swing of the drive shaft center should be $<1\text{mm}$: For the Level of low speed shaft which is more than 1m, it is $<L/1000$ (L is the length of shaft)

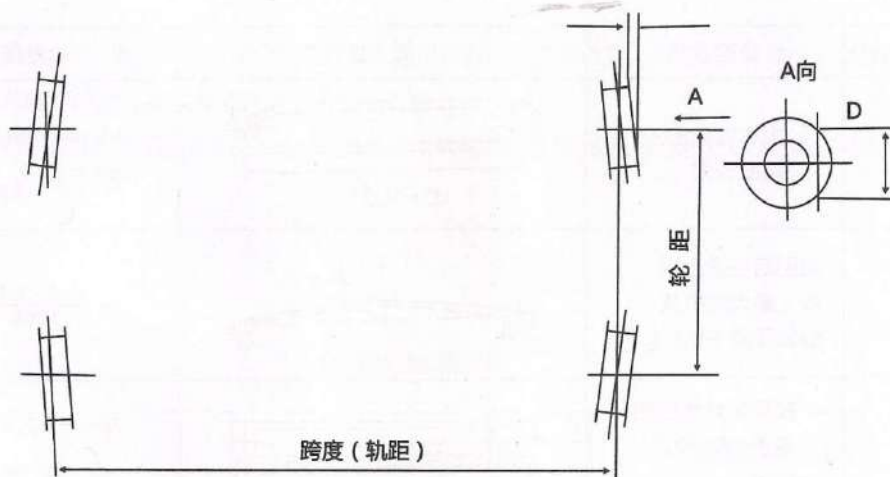
⑤将车轮悬空。用手转动使其旋转一周时不得有卡住现象。如果小车受到意外严重损伤, 调整修复时可以参照上述条款。

⑤Make the wheels be pendent. Use hand to rotate one circle and there should be no jam phenomenon. If the trolley is causing serious damage, the above terms can be as the reference when regulate and repair.

注: (1) 此项只作制造厂或安装单位对金属结构组装的控制指标。以保证运行机构有良好的运行效果, 不作为车轮安装时的考核指标。

(2) 箱形梁的水平旁弯, 在使用过程中会逐渐变小, 甚至会出现由外弯变为内弯, 小车轨距也必然随着主梁的变动从开始的正值偏差, 变为负值偏差。为了使主梁减少人为地变形 (由轨道压板的铲掉和重焊而造成), 故轨距的负偏差在下列范围内仍可使用。

跨中测量: $LQ \leq 19.5$ 米-5 毫米

$LQ > 19.5$ 米-7 毫米

Remark: (1) This item is only for the control objectives of assembly of metal structures by manufacturer or installation institutions. To ensure the traveling mechanism works well, it cannot be the criterion for evaluation when install wheels.

(2) During usage, the level of lateral bending of box type girder will dwindle or even changes from external bending into inward bending, then the gauge of trolley must change from positive deviation into negative deviation along with the change of main girder. To reduce the artificial distortion (shove land re-weld of the rail clamp) of main girder, if the negative deviation of the gauge is in the following area, it still can be used.

Mid-span measurement: $LQ \leq 19.5\text{m}$ -5mm

$LQ > 19.5\text{m}$ -7mm

三、电气控制原理和安装/Third: Control Theory and installation of electrical

(一)、电气控制原理和安装

(一)、Control Theory and installation of electrical

5-125/32 吨电动桥式起重机的电气线路由配电保护电路，各机构的主电路和控制电路，及照明讯号电路组。(请参阅随机附带之电气原理图)

Electrical circuit of 5-125/32t electric overhead crane includes power distribution protection circuit, main electrical circuit and control electrical circuit of each system and lighting signal circuit group. (Please reference the attached Schematic Diagram)

1. 配电保护

1. Power distribution protection

5-50/10 吨电动桥式起重机采用 XQD 型保护箱作为全车的配电保护装置，由隔离开关 DK 和主接触器 XC 作为全车的总电源开关，在 XC 后面引出各机构的主电路和控制电路。

5-50/10t electric overhead crane use XQD type protective cases as the Electrical distribution and protection equipment, and dis-connector DK and main contactor XC as the main switch of the whole crane and lead the main electrical circuit and control electrical circuit of each system behind XC.

在主接触器 XC 的线圈回路中串接有以下操作和保护元件：

In the Coil circuit of main contactor XC, there are the following operation and protection devices:

⊙电锁 DS:是一个带钥匙的按钮，保证只有专职司机才能开动起重机。(仅用联动台操纵的有)

⊙Electrical lock DS: It is a button which is with a key, to ensure that only the full-time driver can drive the crane.(only the crane controlled by Combination Control Console has Electrical lock)

表 2-1/Table 2-1

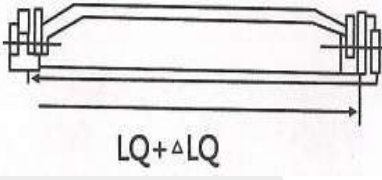
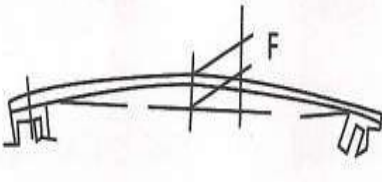
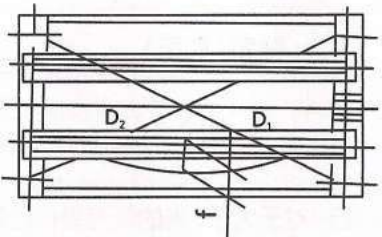
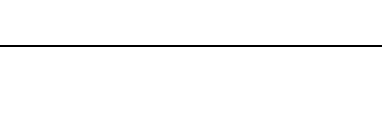
序号 Serial No.	公差名称 Tolerance name	简图 Diagram	公差值 Tolerance value
1	由车轮量出的跨度偏差 Span deviation from wheel		▲Iq=5mm 但相对差 不大于 5mm ▲Iq=5mm Relative difference is not greater than 5mm.
2	装配后主梁上拱度 (最大的拱度控制在跨中 LQ/10 内) Up camber of main girder after assembly (maximum up camber is controlled within LQ/10)		$F = \left(\frac{0.9 \sim 1.4}{1000}\right)LQ$
3	在桥架对角线的偏差 (D1-D2) 注 (1) Crane span structure diagonal deviation(D ₁ -D ₂) Notes(1)		箱型梁 ▲D1≤5mm, ▲D2≤10mm Box girder ▲D1≤5mm ▲D2≤10mm
4	主梁水平旁弯度 (走台和端梁都装上后) Main girder horizontal side camber(after the installation of walking board and main girder)		F≤LQ/2000≤50 吨时 只许外弯 F≤LQ/2000≤50ton, only allow outer bend
5	小车轨距偏差		箱形:跨端 ▲Lx 为±2mm 跨中:

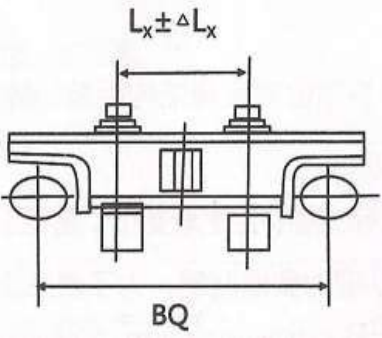
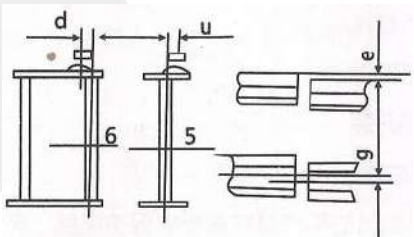
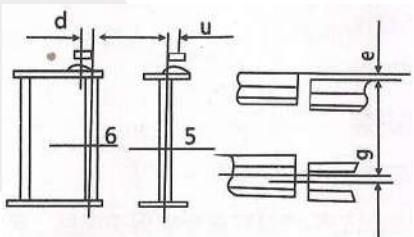
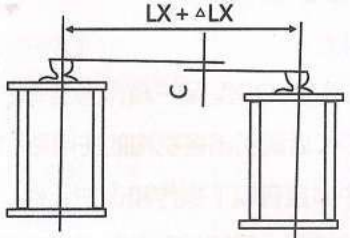
	注(2) Trolley gauge deviation Notes(2)		$LQ \leq 19.5m$, $\blacktriangle Lx$ 为 $+5 +1mm$, $LQ > 19.5m$, $\blacktriangle Lx$ 为 $+7 +1mm$, 单腹板或杠架: $\blacktriangle Lx$ 为 $\pm 3mm$ Box type: End span: $\blacktriangle Lx$ is $\pm 2mm$ Middle span: $LQ \leq 19.5m$, $\blacktriangle Lx$ is $+5 +1mm$, $LQ > 19.5m$, $\blacktriangle Lx$ is $+7 +1mm$, Single web or lever bracket: $\blacktriangle Lx$ is $\pm 3mm$
6	轨道中心线对承轨梁中心线的偏位 The deviation of the track center line to the center line of the bearing rail beam		偏轨箱形 $\delta < 12mm$, $\varkappa \leq 6mm$ 单腹板 $\delta \geq 12mm$, $\varkappa \leq 1/2\delta$ 杠架 $\varkappa \leq 10mm$ Bias-rail box: $\delta < 12mm$, $\varkappa \leq 6mm$ Single web: $\delta \geq 12mm$, $\varkappa \leq 1/2\delta$ Lever bracket: $\varkappa \leq 10mm$
7	轨道接头处中心线偏移差和 高低差 Center line deviation and height difference of track joint		$e \leq 1mm$, $g \leq 1mm$
8	小车轨道高度 (在同一断面上) Trolley rail height (On the same cross section)		$\blacktriangle Lx \leq 2.5mm$ $C \leq 3mm$ $Lx > 2.5m$ $C \leq 5mm$

②启动按钮 QA，在一般情况下接通主接触器 XC 用。

②Start button QA, In general, connect the main contactor XC.

③紧急开关 JK：在事故状态下紧急切断主接触器 XC。切断全车电源，避免事故扩大。

③Emergency button JK: Cut off the main contactor XC in accident state. Cut off the whole car power supply, avoid the expansion of the accident.

④各机构的零位联锁触头 Kx: Kd: Kf: 和 Ks (1-2): 保证主接触器 XC 只有在各机构的操作手柄都在零位时才能接通。避免停电后电源恢复时机构自动启动, 也可避免电动机在转子电阻切除的情况下启动。

④Zero position interlocking contact of each mechanism Kx : Kd :Kf : Ks(1-2) : To ensure the main contactor XC can only be turned on when operating handle of each mechanism is zero position. To avoid automatic start after power recovery and the motor start in case of rotor resistance removed.

⑤栏杆门安全开关 1AK、2AK 和 3AK: 栏杆门被打开, 安全开关的触头也被打开, 则主接触器 XC 断开, 开不了车, 避免有人上下车时开动起重机而造成人身事故。

⑤Handrail door safety switch 1AK, 2AK and 3AK: Handrail door and safety switch contact is turned on. The main contactor XC is cut off, the crane cannot run, to avoid causing personal accident when the crane is just started and people are getting on or off the crane.

⑥总的和各机构的过电流继电器的常闭触头 LJ 和 (1-5) LJ。当某一机构过载或线路短路时断开主接触器 XC, 切断电源。

⑥Normally closed contact of a total and various mechanism over current relays LJand (1-5) LJ. Cut off the power supply and main contact XC when a mechanism is overloaded or line short circuit.

⑦各机构的限位开关 1Xs、2Xs、1Xf、2Xf、1Xd、2Xd、1Xx、2Xx: 当某机构达到极限位置时, 断开主接触器 XC 使机构停止运行。起升机构的两个限位开关都是保护上升的, 用两个开关的目的是可加强可靠性、减少事故率。两个开关具有不同的结构形式, 一个是重锤式, 一个是旋转式, 一般用途的起重机, 其下降方向是不需要限位保护的。如遇特殊情况, 需要下降限位保护时, 现有设备是达不到的, 需提出特殊订货。起升机构也有装一个重锤式限位开关的, 如用户认为没有必要双保护时, 也可选用单保护的。

⑦Limit switch of each mechanism 1Xs、2Xs、1Xf、2Xf、1Xd、2Xd、1Xx、2Xx: when a mechanism reaches its limit position, cut off the main contact XC and stop running the mechanism.

Two limit switches of lifting mechanism are to protect lifting. The two limit switches is designed to enhance the reliability and reduce the accident rate. The two limit switches have different structural forms. One is hammer type. The other is rotation type. The limit protection is not required in the drop direction. In case of special circumstances, if the drop limit protection is required, existing equipment cannot satisfy. And special order is required. There is also one hammer type limit switch for the lifting mechanism, If the users does not need double protection, they can also choose single protection.

在带有修理吊笼的起重机上还附带一个自动空气开关 1ZK, 这是作为全车短路保护用的, 也可作为整车的隔离开关用。为了便于操纵在操纵室内还增加了一个停车按钮 TA 供远距离切断 1ZK 用。

An automatic air switch 1ZK is also attached to a crane with a repair lifting cage. This is used as a full car short circuit protection. It can also be used as isolation switch for a vehicle. In order to facilitate the operation, the operating room also added a parking button TA for long distance of cutting off the 1ZK.

2. 小车运行机构的控制原理

2. Control principle of the running mechanism of the trolley

5-125/32 吨电动桥式起重机的小车运行机构为单电机驱动, 电动机的功率范围 1.5-13KW, 均由 25 安级的凸轮触头直接控制电动机, 其控制原理都一样, 前后各有 5 档, 为了提高起动平稳性, 第一档采

用“电动机转子电阻一相开路”的控制方案。图 3-1 画出了这种控制方案的转子回路接线示意图。这是电动机转子回路串接不对称电阻的特性。此时相当于有一相电阻 (R3) 等于无穷大, 其等效电阻值为相联两相电阻之和, 即 $R_{\text{等效}}=R1+R2$ 。

5-125/32ton trolley running mechanism of electric bridge crane is single motor drive. Motor power range is 1.5-13KW, and is directly controlled by the 25 safety level cam contact. The control principle is the same. In order to improve the starting stability, the first gear adopts the control scheme of "one phase open circuit of motor rotor resistance". Figure 3-1 draws a control scheme diagram of the rotor circuit wiring. This is the characteristic of the motor rotor circuit in series connection with asymmetrical resistance. At this time equivalent to one phase resistance (R3) is equal to infinity. The equivalent resistance value is the sum of the two phase resistance. $R_{\text{Equivalent}}=R1+R2$.



图 3-1

图 3-2

(自然特性: Natural characteristic)

当等效电阻值大于电动机额定电阻值较多时, 其机械特性曲线可以近似地用直线表示。图 3-2 画出了五档机械特性曲线的示意图, 所配 PK 型电阻器具有三个抽头, 当转速为零时, 第一档启动转矩的标称值用调节电阻器抽头的办法, 可获得 0.35、0.5 和 0.7 三种。使用时可根据情况选定一种, 在扣箱、卡活、装配、安装等场合, 要求起动平稳和慢速运行的可选用 0.35 级, 在一般运输用场合, 可选用 0.5 级, 在使用频繁的场所, 为了提高生产率可选用 0.7 级。第二、三、四、五档位常用的电动机转子回路串接不对称电阻逐级起动的控制方案。逐级推动手柄, 凸轮出头逐级短接电阻, 电动机逐级起动。最后一个位置, 电阻没有全部被短接, 有两端电阻并联后接在一相中, 电动机工作在特性 5 上, 驱动小车以稍低于额定的速度运行。

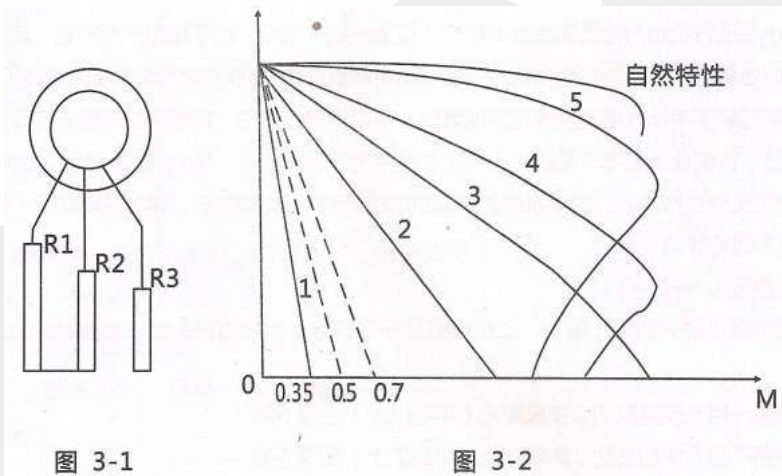
When the equivalent resistance value is greater than the rated motor resistance value more, the mechanical characteristic curve can be approximated by a straight line. Figure 3-2 depicts a schematic diagram of the mechanical characteristic five-speed, the type with PK resistor has three taps, when the speed is zero, the first tranche of the nominal value of the torque start by adjusting the resistance tap approach may get 0.35, 0.5 and 0.7 three kinds.

When used select one according the circumstances, in the situation of button box, the card live, assembly, installation, and other occasions, requires a smooth and slow start operation can be used 0.35, in the general case of transportation, the choice of 0.5, in the frequent use occasions, can be used to increase productivity 0.7.

Second, third, fourth and fifth gears commonly used in the motor rotor circuit in series resistance control scheme asymmetrical progressively start. Progressively push the handle, cam head progressively short resistance, motor starters step by step. Last position, not all resistance is shorted, there are two ends of the

resistor in parallel followed by a phase of work on the characteristics of the motor 5, drive the car to a little less than the rated speed operation.

3. 大车运行机构的控制原理

3. The control principle of the traveling mechanism

大车运行机构均采用双电机分别驱动。电动机功率范围为 2x(3.7-30)千瓦。

Traveling mechanism are dual-motor drive, respectively. Motor power ranges from 2x (3.7-30) kilowatts.

双电机驱动, 电动机功率为 2x (5-7.5) 千瓦的, 用 60 安级凸轮控制电动机的定子, 用 25 安级的凸轮触头控制电动机的转子。

Dual-motor drive, motor power is 2x (5-7.5) kilowatts, with 60 press stage cam control motor stator, using 25 security-level contacts cam control of the rotor of the motor.

双电机驱动, 电动机功率为 2x(11-30)千瓦的, 用 CJ12-100 接触器控制电动机的定子, 用 60 安级的凸轮触头控制电动机的转子。接触器安装在保护箱内。大车运行机构的控制原理, 除第一档增加花型档以外, 其余均与小车运行机构相同, 增加滑行挡后, 在停车时, 先打到第一挡, 此时电动机停电而制动器不停电, 机构可继续滑行, 待到目的地后再回零位, 制动器断电刹车, 使机构停住, 这样可以把大车制动器调整得紧些, 既保证了平稳停车, 又保证把大车制动住。遇紧急情况时, 可直接打到零位停车, 保证安全。

Dual-motor drive, the motor power is 2x (11-30) kW with CJ12-100 contactor control motor stator with 60 security-level contacts cam control of the rotor of the motor. Contactor installed in a protective box. Control Principle traveling mechanism, in addition to the first tranche of the increase flower stalls, the rest are the same as with the trolley traveling mechanism, the increased sliding block, when stopping, hit the first stop, then the motor power and brake without power, institutions may continue to slide, until the destination and then back to zero, the brake power brakes, stopped making mechanism, so you can put the cart brake adjustment borne more, both to ensure a smooth stop, but also to ensure the brake carts live. When an emergency situation happens, can direct hit zero parking, and ensure safety.

4. 起升机构的控制原理

4. Control Principle of hoisting mechanism

5-125/32 吨电动桥式起重机的起升机构为单机驱动, 电动机的功率范围为 13-75 千瓦。

5-125 / 32 ton electric bridge crane hoisting mechanism for the stand-alone drive, the motor power range of 13-75 kW.

电动机功率为 13-22 千瓦的, 用 60 安级的凸轮触头直接控制电动机。

13-22 kW motor power, use the 60 cam contact direct control the motor.

电动机功率为 30-75 千瓦, 用主令触头通过 XQR2 型控制箱控制电动机。

Motor power from 30 to 75 watts, use contact by XQR2 master control box controls the motor.

用凸轮触头直接控制电动机的控制原理就是通常用的电动机转子回路串联不对称电阻逐级起动的控制方案和大小车运行机构的控制原理基本相同, 仅第一挡不采用"转子电阻一相开路"而是一般的不对称电阻。在下降负载时, 由于是位能负载, 负载带动电动机旋转, 使电动机超过同步速度而进入发电制动状态, 这时如果在转子中串入电阻反而使速度增加, 所以下降负载时, 应特别注意这一点, 不要在前面几挡停留时间过长, 否则会出现飞车现象。

Direct contact with the cam control motor control principle is commonly used in the motor rotor circuit resistance asymmetric tandem control scheme step by step starting size and control principle is basically the same car running mechanism, fail to do so using only the first "open rotor resistance of a phase" but generally asymmetric resistance.

When the load drops, as it is the potential energy load, load drive motor rotation, motor power than synchronous speed into the braking state, then if the resistor in series with the rotor speed increases but to

make, so the decline in load, special attention should be this, do not stop in front of a few to stay too long, otherwise there will be runaway phenomenon.

用主令触头通过 XQR2 ,型控制箱控制电动机的控制原理比较复杂, 详细说明如下: 线路特点:
Through contact with the master XQR2, control box controls the motor control principle is more complex, as detailed below: Line Features:

- ① 可逆不对称线路;
 - ② 主令挡数为 3—0—3 ;
 - ③ 起动电阻级数为四级; 第一' 二级电阻系手动切除, 其余由延时继电器控制的加速接触器自动切除;
 - ④ 下降第一挡为反接制动, 实现重载(半载以上)慢速下降;
 - ⑤ 下降第二挡为单相制动, 实现轻载(半载以上)慢速下降;
 - ⑥ 下降第三挡为强力下降或再生发电制动, 用于各种负载的快速下降;
 - ⑦ 停车时, 制动器先断电, 0.6 秒电动机再断电, 以防溜钩;
 - ⑧ 为防止主接触器 ZC—DC、DC—FC 可逆转换时造成相间短路, 采用换向继电器 ZDJ。线路具有过载、短路、限位、零位和失压保护。
1. Reversible asymmetric lines;
 2. Master block number is 3-0-3;
 3. Starting resistance level is four; the first 'Manual Secondary resistance line removal, and the rest by the acceleration delay relay contacts controlled automatic excision;
 4. Falling first stop for the reverse braking to achieve overloading (more than half load) a slow decline;
 5. Falling second gear for the single-phase brake light load (more than half load) a slow decline,
 6. Falling third gear is a strong decline in regenerative braking power for the rapid decline of various loads;
 7. When the parking brake power off, 0.6 seconds off the motor again to prevent slip hook;
 8. To prevent the main contactor ZC-DC, causing phase short circuit, when using DC-FC reversible conversion reversing relay ZDJ. Circuit have overload, short circuit, limit, and zero voltage protection.

在电动机定子回路中接有隔离开关 IDK ,换向接触器 ZC 和 FC ,单相制动接触器 DC ,过电流继电器 1LJ 和 2U ,制动接触器 ZDC ,制动器通过 ZDC 供电,而不像凸轮触头直接控制电动机那样,制动器与电动机直接并联,因为此线路下降方向分别采用了反接,单相和再生发电制动。而每种制动都有各自的线路接触器控制,在下降过程中,三个接触器多次换接。在换接的瞬间电动机是断电的。如制动器直接与电动机并联。则在电动机断电瞬间制动器也将断电而抱闸,这对运行是不利的。另外,在单相制动时,电动机仅有两相电源,制动器不能保证可靠工作,所以制动器必须单独供电。

In the motor stator circuit is connected with isolation switch IDK, reversing contactors ZC and FC, single-phase brake contactor DC, over current relays 1LJ and 2U, brake contactor ZDC, brake power through ZDC, unlike cam contact head direct control of the motor as a direct parallel with the motor brake, because the decline in the direction of the line were used reverse, single-phase power generation and regenerative braking. And each has its own brake line contactor control, during descent, three contact times for access. Grafting in the moment of the motor is powered off. The brake directly is in parallel with the electric motor. At the moment the motor power and power brakes will brake, which run at a disadvantage. In addition, single-phase braking, the electric motor only two-phase power, brakes are not guaranteed to work, so the brake must be power supplied separately.

在电动机定子回路中接有一级反接电阻, 三级加速电阻和一级软化电阻。

In the motor stator circuit is connected with a reverse resistance, three acceleration resistance and a softening resistance.

升降机构系位能负载。为了改善使用性能，此线路的上升和下降具有不同的工作特性。图 3—3 画出了其机械特性。上升时，特性 1、2、3 分别对应于主令手柄位置第 1、2、3 档，可稳定运行，特性 1 和 3 是由延时继电器自动过渡的，不能稳定运行，这些特性是用在转子回路中串接不同电阻值的方法得到的，主要用作电动机的起动，也可用来调速，（由于电阻特性很软，所有轻负载不能调速）但是由于电阻器是按起动条件设计的，所以不允许长期使用，仅适用于较大负载的短距离慢速上升。Lifting mechanism is allowed load . To improve performance, the rise and fall of this line have different operating characteristics. Figure 3-3 depicts its mechanical properties. The rising characteristic 1,2,3 correspond to the master file handle position 1,2,3, stable operation, characteristics 1, and the transition from 3_ automatic delay relay cannot be stable operation of these features are in the rotor circuit in series with different resistance values obtained by the method, mainly for motor starting, it can also be used to control, (due to the resistance characteristic is very soft, not all light-load speed) but because the resistor is based on starting conditions design, long-term use is not allowed, only for a heavy load of short-range slow rise.



图3-3



图3-4

下降时，也有三条稳定工作特性 1、2、3 和两条过渡特性 3'3''。下降第一档采用反接制动，此时接触器 ZC 闭合，电动力矩是上升方向的，由于转子中串接有较大电阻，电动机的力矩是不大的，如若负载大于 55% 额定负载（重载）时，负载就把电动机倒拉下去而使它反着磁场旋转的方向转动，这就是反接制动状态。不允许长期使用，仅适用于重载短距离慢速下降。

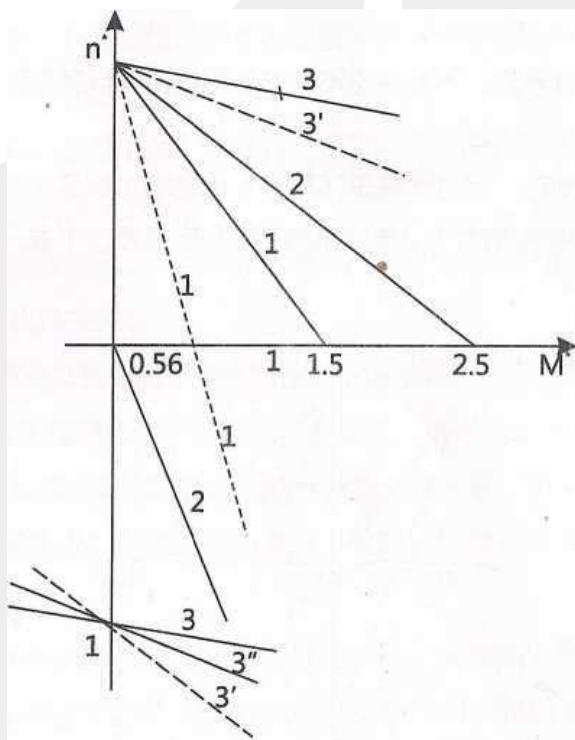
When it dropped, there are three stable operating characteristics, 1, 2, 3 and two transition characteristics 3'3''. Drop the first tranche adopt the reverse braking. At the same time, ZC contactor is closed and the electric moment is raising direction. Since series with a larger rotor resistance, motor torque is small. If the load is greater than 55% of the rated load (Overload), the loads put down the motor and pull it down with anti-rotation of the magnetic field direction, which is reverse braking. Long-term use is not allowed, only short distances for heavy slow decline.

下降第二档采用单相制动，此时接触器 DC 闭合，单相制动不仅克服了反接制动状态。不允许长期使用，仅适用于重载短距离慢速下降。

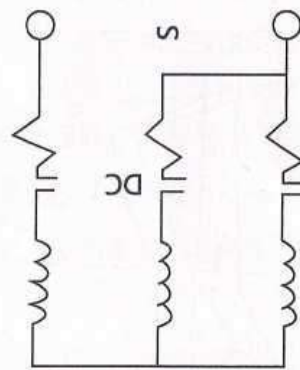
Drop the second tranche uses single braking phase, while DC contactor is closed. Single-phase brakes not only overcome the reverse braking. Long-term use is not allowed, only short distances for heavy slow decline.

下降第二档采用单相制动,此时接触器 DC 闭合,单相制动不仅克服了反接制动出现轻载上升的缺点,也克服了再生发电制动没有低速段的不足。如选择适当的转子附加电阻,可得到轻载慢速下降特性。Drop the second tranche uses single braking phase, while DC contactor is closed. Single-phase brakes not only overcome the reverse braking which has the shortage of light loads up, but also to overcome the regenerative braking power is no less than the low-speed sections. If you choose the appropriate rotor resistance, the slow decline can obtain available light load characteristics.

单相制动按图 3-14 的接线发接线,电动定子绕组两相并联后与另一相串接到两相上,此时电动机定子三相加的是不对称电压,不对称电压可以分解正序电压和逆序电压。经过分析计算可以证明,正序电压和逆序电压的有效值相等,并等于电网电压 $1/\sqrt{3}$ 。因电动机的力矩与电压的平方成正比,所以正序电压和逆序电压所产生的正序和逆序最大转矩也相等,并在数值上等于电动机正常运转时最大转矩的 $1/3$ 。

After the single-phase brake according to the wiring made wiring diagram 3-14, the electric two-phase stator windings in parallel and in series with respect to the other two phases, then the sum of the three motor stator voltage is asymmetric, asymmetric voltage can be decomposed positive sequence voltage and reverse voltage. After analysis and calculation can be shown that the positive sequence voltage and reverse voltage RMS equal, and equal to the grid voltage of $1/\sqrt{3}$. Due to torque of the motor is proportional to the square of the voltage, the positive and reverse positive sequence voltage and the maximum torque generated by the reverse voltage are equal, and the normal operation of the motor is equal to $1/3$ of the maximum torque value.

图 3-5 画出了按图 3-4 接线法在转子滑环短接时的机械性曲线。曲线 1 是正序力矩,曲线 2 是逆序力矩,曲线 3 是合同力矩。合同力矩在一、三象限是电动力矩。且转速为零,合成力矩也为零,该特性既不能自行起动,也不能做下降制动用。因此必须在电动机转子回路中加入适当的电阻使特性软化,合成力矩由一、三象限逆时针转到二、四象限,变成制动力矩,才能得到我们需要的单相制动特性,如图 3-6。

Figure 3-5 depicts mechanical curve in Figure 3-4 Wiring Method rotor slip ring short time. 1 is a positive sequence torque curve; the curve 2 is a reverse torque, torque curve 3 contract. Contract moment in a three-quadrant is electric torque. And the speed is zero, the resultant moment is zero, this feature is neither self-starter, do not fall brake. Must therefore be added to the appropriate motor rotor circuit resistance in softening properties make synthetic torque by a third quadrants counterclockwise to the second and fourth quadrants, into braking distance in order to get single-phase braking characteristics we need, such as Figure 3-6.

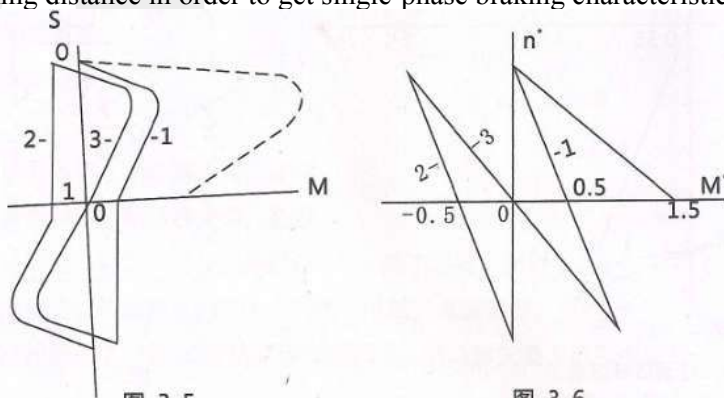

单相制动用于轻载时,当额定负载、重载时的低速下降档,当需要低速下降时就不要用这一档,需要低速但负载大于 55%额定负载时不要用这一档,而应使用第一档反接制动。当无法估计负载大小时,

可以先试吊一下，然后再正式搬运。单相制动时电流较大，其中一相可达 1.6-2.1 倍额定电流，主要与转子电阻有关。现在采用的是 67% 额定电阻。电阻过大将使特性变陡，下降速度加快，电阻过小招致电流过大。

Do not use this file for a single-phase braking load is less than 55% of the rated load (light load) during the slow fall, do not use this file when you do not need to slow down but need low load greater than 55% of the rated load. Instead, use the first gear reverse brake. When you can not estimate the size of the load, you can try lifting it, then formal handling. Single-phase braking current is large, a phase in which up to 1.6-2.1 times the rated current, the resistance of the main rotor. Now it uses 67% of the nominal resistance. Resistance is too large will cause characteristic becomes steep decline accelerated; resistance is too small lead to excessive current.

以上两档用于慢速下降，即用作调整性移动。不允许也不应该长期使用。以免电动机和电阻器过热损坏。

Those two tranches are for a slow decline, which is used to adjust the resistance movement. Long-term use should not be allowed in order to avoid the motor overheating and damage resistance.

下降第三档采用强力下降或再生发电制动。此时接触器 FC 闭合，电动机力矩是下降方向的，下降空钩或轻负载时（轻到不足以克服驱动装置的摩擦阻力），电动机把空钩和轻负载送下去。工作在第三象限为强力下降。下降较重负载时，负载将拖着电动机使转速增加，当转速大于同步速时，电动机即工作如与电网并联的发电机，将负载的动能变成电能，然后反馈给电网，工作在第四象限，为再生发电制动，用于各种负载的快速下降。

Drop the third tranche of the use of regenerative braking power or strength decreased. In this case contact FC closed, the motor torque direction is decreased, down empty hook or light loads (light enough to overcome the frictional resistance to the drive unit), the empty hooks and light motor load sent down. In the third quadrant of strength decreased. Drop a heavy load, the load will make dragging motor speed increases when the speed is greater than the synchronous speed, the motor that is working like a parallel with the grid of the generator, will fail to load into electrical energy and fed back to the grid, in the first four-quadrant, regenerative braking power for the rapid decline of various loads.

三个接触器 ZC、FC 和 DC 之间有电气联锁，即在某一接触器线圈回路中串联其余两个接触器的常闭付触头。这在正常情况下能起联锁作用，而避免电源短路。但是如常闭付触头调节不好，或在频繁接通条件下触头开距变动了，再加上操纵过快，就有可能在一接触器的电弧未完全熄灭前而另一接触器就接通，而造成弧光短路。同时利用 ZDJ 的短路暂延时，在主令手柄由零位快速推到下降 3 或由 3 快速推回零位时，DC 不动，从而减轻了 DC 的工作。

There are between three contactors ZC, FC and DC electrical interlock that a contactor coil in series with the circuit remaining two contacts normally closed contacts pay. It can play a role in interlock under normal circumstances, avoid short to power. But normally closed contacts adjust pay well, or frequently switched under contact opening distance change, coupled with excessive manipulation, it is possible in front of a contact arc is not completely extinguished and another contact on turned on, causing a short circuit arc. While taking advantage of ZDJ short temporary delay in the master handle the zero position to rapidly push down 3 or pushed back by three quick zero position, DC does not move, so as to reduce the DC job.

反接电阻在上升过程中是作为过渡状态出现的，起预备级作用，在反接触器 FJC 线圈回路中，串联了延时继电器 2LSJ 的延时闭合常闭触头。当主令手柄在零位时，2LSJ 线圈获电，打开其接在 FJC 线圈回路中常闭触头。将手柄推至上升 1 时，由于 ZC 接通，打开其接在 2LS 线圈回路中的常闭付触头，使 2LS 的线圈断电，经延时 0.2 秒后，闭合其常闭触头，使 FJC 线圈供电，将反接电阻切除，机械特

性由过渡性 1'自动过渡到工作特性 1 上。

Reverse resistance during ascent is emerging as a transitional state, from the preparatory stage role in the anti-FJC contactor coil circuit in series delay relay 2LSJ delay closing the normally closed contacts. When the master handle in zero position, 2LSJ electrical coil is eligible to open its coil loops connected to the FJC often closed contacts. Push the handle rises to 1, the ZC turned to open its connected 2LS coil loop to pay NC contacts, make 2LS coil power, by the delay 0.2 seconds after closing the normally closed contacts so FJC coil power supply, reverse the removal resistance, mechanical properties by the transitional 1 'automatic transition to the working characteristics 1.

在单相制动或再生发电制动下降时，反接电阻不参加工作，应切除。所以在 FJC 线圈回路中的 2LSJ 常闭触头并联了 DC 和 FC 的常开付触头，当 DC 或 FC 接通时，2LSJ 不起作用，而通过 DC 或 FC 的付触头使 FJC 接触，切除反接电阻。

In the single-phase power generation regenerative braking or when braking decline, reverse resistance does not participate in the work, it should be removed. So 2LSJ at FJC coil loops in parallel with the normally closed contacts DC and FC normally open contact payment, or when the DC FC turned on, 2LSJ does not work, or pay through DC contacts FC FJC makes contact resection reverse resistance.

当手柄位于上升 2 时，加速接触器 LJSC 接通，切除第一级加速电阻，使电动机加速，转到工作特性 2 上运行，由于在 1JSC 线圈回路中串接了 FJC 常开付触头，只有 FJC 接通后才能接通 1JSC，保证电动机逐级平稳加速。

When the handle is up 2 to accelerate contacts LJSC turned on, the first cut resistance level acceleration, the motor is accelerated to the operating characteristics of the 2 runs, as the series of FJC in 1JSC fine circle circuit normally open contact pay, only after the FJC is turned on first 1JSC, step by step to ensure the smooth acceleration of the motor.

当手柄位于上升 3 时，2JSC 接通，切除第二级加速电阻，电动机加速，工作在过渡特性 3' 上。但 2JSC 必须在 1JSC 线圈回路中串接了 FJC 常开付触头，只有 FJC 接通后才能接通 1JSC，保证电动机逐级平稳加速。

When the handle is increased by 3, 2JSC turned on, the second cut resistance level acceleration, and the motor accelerates the transition characteristics in 3 '. But 2JSC series must pay the FJC normally open contacts only after FJC 1JSC turned on first, to ensure smooth acceleration of the motor stepwise in 1JSC fine circle loop.

当手柄位于上升 3 时，2JSC 接通，切除第二级加速电阻，电动机加速，工作在过渡特性 3' 上。但 2JSC 必须在 1JSC 接通 0.6 秒后才能接通，因为 2JSC 线圈回路中串接有延时继电器 3LSJ 的延时闭合常闭触头。2LSC 接通后，断开其接在 4LSJ 线圈回路中的常闭付触头。2LSC 接通后，断开其接在 4LSJ 线圈回路中的常闭付触头，使 4JSC 线圈断电，经 0.3 秒后闭合其常闭触头，使 3JSC 接通，切除第三级加速电阻，使电动机再次加速，在工作特性 3 上运行。

When the handle is increased by 3, 2JSC turned on, the second cut resistance level acceleration, and the motor accelerates the transition characteristics in 3 '. But 2JSC must get through in 0.6 seconds after turning 1JSC because 2JSC coil loop in series there is a delay relay delay 3LSJ closing the normally closed contacts. 2LSC Once connected, disconnect the connected 4LSJ coil loop to pay NC contacts. 2LSC Once connected, pay off the normally closed contacts connected 4LSJ coil loop, so 4JSC coil power, by 0.3 seconds after closing the normally closed contacts so that 3JSC turned on, cut the third level acceleration resistance, the motor is accelerated again, running on the operating characteristics 3.

为了避免停车时负载溜钩，在线路中考虑了在停车时让制动器先抱闸，电动机后停电，以保证停车时电动机有一个上升力矩，以减轻溜钩。主令触头 5 和延时继电器 1LSJ 的延时分开常开触头组成的串

联回路，与主令触头 4 相并联。当手柄由上升 1 或下降 1 推零位时，触头 5 闭合，1LSJ 由于 ZDC 释放而断电，经 0.6 秒后才打开其已闭触头，在此期间 ZC 是接通的，而 ZDC 已断电，因此实现了先抱闸后停电动机的要求。

To avoid parking slip hook load, considered in line at the time of the parking brake to allow the brake after the motor power, to ensure that when there is a rise in the motor stop torque, in order to reduce slip hook. Master 5 contacts and time delay relay delay 1LSJ separate normally open contact composed of a series circuit with the master contact 4 in parallel. When the handle 1 by a rise or fall 1 push zero, the contact 5 is closed, 1LSJ due ZDC release of power by 0.6 seconds after it has been closed contacts to open during this period ZC is turned on, and the ZDC has power, thereby realizing a first brake after stopping the motor requirements.

此线路下降方向的三个档位都是独立工作的。操纵时不必遵循 1-2-3 的次序，应根据浮载重量，下降速度和下降距离的要求，正确选择挡位，果断地操作。

This line of descent direction three stalls are working independently. When the manipulation is not necessary to follow the sequence 1-2-3, and should be based on a floating load, speed and fall under Long distance requirements, choose the right gear, decisive action.

各种负载的快速下降：手柄从零位直接推到下降 3，在工作特性 3 上，进行强力下降或再生发电制动下降。电动机的启动由 3LSJ 和 4LSJ 来控制，自动逐级进行，中间有两级过渡特性 3' 和 3''。

The rapid decline of various loads; handle direct push from zero to a decline of 3, on the operating characteristic 3, for strong decline or in regenerative braking decline with power. Start the motor by 3LSJ and 4LSJ controlled automatic level by level, there are two transition characteristic 3 'and 3. "

轻负载慢速下降：手柄从零位先推到下降 2 或下降 3，再回到下降 1，工作在特性 1 上，进行反接制动下降。

Decline slowly when light load: first push the handle from the zero position to decline by 2 or 3, then fell back to 1, work on the characteristics of 1, with reverse braking decline.

如重物距放落地点较高时，应将手柄推到下降 3，当重物接近放落地点时，再根据负载的轻重将手柄返回至下降 2 或下降 1，这样可缩短单相或反接制动的动行时间，减少电动机和电阻器的发热。

When the distance between heavy goods and landing point is large, the handle should be pushed to decline of 3, when the heavy good near to the landing point, the handle should be fell back to decline of 2 or decline of 1 according to the load, which can shorten the time of single-phase or reverse then the dynamic brake, and reduce heating level of motor resistor.

为了避免下降轻负载时反而上升的现象，手柄由零位推向下 1，机构是不能运行的，只有从下降 2 或下降 3 推回下降 1 时，才能进行反接制动下降。也就是说，重负载时，先打至下降 2 或下降 3，达不到慢速要求时，再推至下降 1，这是由联锁继电器 1LSJ 实现的。当手柄在零位时，1LSJ 不接通。当手柄由零位推至下降 1 时，1LSJ 仍不接通，它的两个常开触头使 ZC 和 ZDC 都不能接通，机构不能运行。而当手柄推至下降 2 或下降 3 时，由于 DC 或 FC 的接通，使 1LSJ 接通，而使常开触头闭合。此时，如将手柄退回下降 1，ZDC 由于 1LSJ 的闭合而接通。而 1LSJ 亦由于 ZDC 的增闭合而接通，实现了互保。由于 1LSJ 的接通，使 ZC 和 ZDC 接通，进行反接制动下降。为了保证上升时不受此环节影响，而能打开制动器。在 ZDC 线圈回路中的 1LSJ 触头上并联 ZC 的常开付触头，只要 ZC 接通，ZDC 也接通。

In order to avoid the drop but increased during light load, push the handle from zero to decline of 1, mechanism can not be run, only push from the decline of 2 or 3 back to 1 to perform reverse braking decline.

That is, when heavy load, push to decline of 2 or 3 in advance, if can't meet the slow speed requirements, push to decline of 1, which is come true by interlocking relay 1LSJ. When the handle is in the zero position, 1LSJ not turned on. When the handle is pushed from zero position to decline of 1, 1LSJ still not turned on, there are two normally open contacts to make a ZC and ZDC can not turned on, the mechanism can not run. When the handle is pushed to decline of 2 or 3, since the DC or FC is turned on, so that 1LSJ turned on, and make the normally open contact is closed. At this time, if the handle returned to decline of 1, ZDC closed due 1LSJ turned on, and 1LSJ also increase due ZDC closed and turned to achieve a mutual insurance. Since 1LSJ is turned on, so that ZC and ZDC turned carried reverse braking decline. In order to ensure that rising is not influence by this part, and can open the brake. Composed 1LSJ contact of ZDC loop coil circuit and ZC normally open contacts in parallel, as long as ZC turned on, ZDC also turned on.

5.照明讯号电路

5. Lighting signal circuit

在保护箱内设有照明讯号电路的隔离开关 3ZK ,它与主隔离开关 DK 并联,当检修时,切断 DK ,而照明讯号电路仍能工作。

In the control box with lighting protection signal circuit isolation switch 3ZK, it connect with the main isolating switch DK parallel, and cutting DK when overhaul,lighting and signal circuit can still work.

照明有操纵室照明、手提检修照明和桥下照明三种,手提检修照明采用 36V 安全电压,操纵室和桥下照明采用 220 伏电压,由 380/220、36V 次级双绕组变压器供电。所有灯开关都装在操纵室内。 Lighting include Illumination control room lighting, portable maintenance lighting and bridge lighting, portable maintenance lighting with 36V safe voltage, control room and bridge lighting with 220 volts, power supply by 380 / 220,36V double secondary winding transformer. All light switches are installed in the control room.

桥下照明采用 ZF001F-G 型防震灯具灯泡为 450 瓦,跨度大于 16.5 米的装三个,其余装两个。

Bridge lighting using ZF001F-G quakeproof type lamp, bulb is 450 watts, if span length is more than 16.5 m it need three lamps, otherwise install two lamps.

音响讯号采用 36V6 吋电铃。

Acoustic signal using 36V6 bell.

其余备有 220 伏插座一个,供插接电风扇等设备用和 36V 插座一个,供插接检修灯用。如在订货合同上提出要求,还可随车附带电风扇、电热器、冷风机或空调器。

Rest with a 220-volt socket for plug fans and other equipment and a 36V socket for plug inspection lamp. If requested by the contract, also could comes with electric fans, electric heaters' cooler or an air conditioner.

6、操纵/ Operation

所有操纵元件全部装在操纵室内,各机构控制器均匀地分布在司机的周围,启动按钮、紧急开关、电铃等也能方便地操作。

All components are all mounted in the control room, each controllers evenly distributed around the driver, it is easy to start button, emergency switches, bells, etc..

如采用联动操纵台在联动操纵台上装有控制机构运行的控制器,电源指示灯,电锁、起停按钮紧急开关、脚踏电铃开关等电器元件。

If use linkage controller there should install remote control of mechanism travelling, the power indicator, power locks, emergency start-stop switch, foot bell switches and other electrical components.

大、小运行机构由_个手柄操纵,纵向控制小车、横向控制大车,两机构可以单独操纵,也可以同时操纵。双钩起重机的主、付钩运行机构分别由两个手柄操纵。

Crane and winch travel mechanism control by pendent, it control winch vertical travel and crane lateral travel, crane and winch can be individually manipulated and also can be manipulated at the same time. The main hook and auxiliary hook of double hook crane are operated by two pendent.

(二) 电气设备的安装与调整

(二) Installation and adjustment of electrical equipment

电气设备的安装和电线的敷设应按所附的电气原理图、配线图、电气设备总图、以及本节的规定进行。Installation of electrical equipment and wiring shall be refer to accompanying schematics, wiring diagrams, electrical equipment general drawing, and the provisions of this section.

安装前应详细地熟悉上述电气图与技术条件,了解各元件的相互作用和操作原理,以求能迅速地处理安装及试车中所发生的问题。

Before installation should be familiar with the above detailed electrical diagrams and technical conditions to understand the interaction concept of operations of each part, in order to solve the problems quickly during installation and commissioning.

安装前应清理和检查全部电气设备和元件。所有的电气设备和元件应无缺陷,运转应灵活、不允许有卡住和松动等现象。电气设备和元件的型号,规格.触头關合次序等必须符合图纸。需要调整的应按图纸规定调整好。

Should clean and inspect all electrical equipment and components prior to installation. All electrical equipment and components to be free of defects, the operation should be flexible, not allowed to have loosening and stuck phenomenon. All the electrical equipment and components model, specifications contact closing sequence must conform to the drawings. Otherwise should be adjusted with the drawings.

现将主要电气设备和元件的检查、调整和安装要求分述如下:

Now list the requirements of the main electrical equipment and component inspection, adjustment and installation as follows:

1. 电动机/ Motor

首先作一般性外观检查,转动联轴器观察转子是否转动灵活,并用兆欧表测定其绝缘电阻.定子大于 1.5 兆欧,转子大于 0.8 兆欧即可使用,否则应予烘干。烘干的方法可装入烘箱,也可通入低压短路电流,即将各相绕组首尾串联接于 50 伏以下电源,电动机处于堵转状态,其电流应不大于额定值,上面盖以帆布,上下留进 出风口,温度要逐步上升。三小时后保持电动机表面温度不超过 50-60°C,热态下测得定子达 1 兆欧,转子达 0.5 兆欧以上,即称合格。

First, make a visual inspection of the general and rotation of the coupling to check if the rotor is rotating flexible and measure the insulation resistance by tramegger, megger stator should be greater than 1.5 megohms, the rotor should be greater than 0.8 megohms, or should be dry. Drying method can be loaded into the oven or pass into the low-voltage short circuit current, that is each phase winding connected in series to 50 volts power supply, the motor is locked-rotor, the current should not exceed the rating value, covered with canvas, stay wind inlets and outlets on the top and bottom, the temperature should be gradually increased. After three hours keeping the motor surface temperature does not exceed 50-60 °C, measured the stator up to 1 megohm, rotor up to 0.5 megohms minimum in hot state, that is called qualified.

刷架弹簧需调整到 1.5-2.0 牛顿 2/1 厘米 2 的压力,一台电动机的所有炭刷压力必须一样。电动机炭刷与刷握之间空隙不应大于 0.2 毫米,但也不宜过紧,否则将使炭刷磨损过大。炭刷应与滑环全面接触,磨炭刷时不应磨圆其边缘。

Brush holder spring adjusted to the pressure 1.5-2.0 Newton 2/1 cm², all carbon brush pressure must be the same for one motor. The gap between the motor carbon brushes and brush holder should not be more than 0.2 mm, but not too tight, otherwise it will cause excessive wear of carbon brushes. Carbon brushes should be fully in contact with the slip ring, when wear carbon brush should not wear round the edges.

2. 电磁铁/ Electromagnet

用兆欧表测定其绝缘电阻，大于 1.5 兆欧即可使用，否则应予烘干。

安装时需检查其活动部分是否有松动，偏斜或卡住现象，并应清除其活动部分和磁铁接触面的铁锈及其它污物。磁铁工作时其接触面间不应有空隙，如有则必须进行调整，清除空隙。

Measuring the insulation resistance by megger, more than 1.5 MΩ can use, otherwise should be dry.

When installation, should check whether the activities part is loose, deflection or jam phenomenon, and remove rust and other contaminants of the activities part and magnet contact surface. The contact surface should not have gap when the magnet works, if any gap, must be adjusted and clear the gap.

3. 联动操纵台或控制器/ Linkage control console or controller

各触头的结合面应为线接触，压力依触头大小约 10-17 牛顿，由压紧弹簧的螺母来调整。

各联接螺钉应旋紧，接触应良好。操作手柄应灵活，档位应明显。

The combination of the contact surface shall be the line contact, pressure in accordance with the size of about 10 to 17 N, by the compression spring nut to adjust

All wiring should tighten screw, keep good contact. Handles should be flexible, block should be obvious.

4. 电阻器/Resistor

各机构电动机所配用的电阻器，是根据电动机的规格，控制方式以及工作类型的不同，或选用通用的电阻器，或用专门设计的电阻器。

All motors matched resistors, is according to the specifications of the motor, control mode and different type of work, or with general electric resistance, or use a specially designed resistor.

电阻器的接线必须按提供的资料正确联接。如果发现电动机出力不足，控制手柄在规定位置不能起吊额定负载或开动大小车。首先应检查电阻器的接线是否有错。

Resistor connection must be connected properly according to the information provided. If it is found that the motor output under capacity, control handle in the specified location not lifting rated load or to start the car.

First check if there is a wrong connection of resistor.

对于双电动机驱动的机构，所配用的电阻器应作适当的选择调整。电阻值较大的电阻器（既有 "+" 向允差者），应用于距操纵室较近的电动机，或用于滑差允差为 "-" 的电动机。

For double motor drive mechanism, the matched resistor should make proper choice adjustment. Resistance value of the larger resistor (both "+" to allow memory), applying to the motor close to control room, or to slip tolerance for "-" of the motor.

也就是说两台电动机的软化电阻应尽量保持一致，软化电阻包括电动机内电阻，联接线电阻与电阻器中长期接入的那段电阻。（用凸轮触头直接控制转子电阻的控制方式没有常接电阻）如有条件调整电阻器的常接电阻值，使两台电动机的机械特性完全一致是最理想的。

That two motors softening resistance should be as consistent as possible, softening resistance include inter resistance, the connecting wire resistance and the resistor long-term access. (the control mode by direct contact with the control cam rotor resistance is no always - connection resistor) if the conditions of constant adjusting the resistance of resistor values,

The mechanical performance of two electric motors exactly is the most ideal.

电阻器安装时应注意下列问题

Resistor installation should pay attention to the following issues

① 四箱及四箱以下的电阻器可以直接叠装在一起。四箱以上的电阻器最好装在电阻器架上，各箱之间距离 80 毫米，中间还可以添加隔热板，以减少最上部电阻器的温升。

Four boxes and below four boxes resistor can be directly stacked together. Four above boxes resistor is preferably provided on the resistor frame, 80 mm distance between each box, in the middle of boxes you can

also add intermediate insulating panels to reduce the uppermost resistor temperature rise.

② 电阻器架的布置,应考虑到便于检修和更换电阻元件,有利于散热,架前通道应不小于 600 毫米,电阻元件与墙壁和地板的距离应不小于 150 毫米。

Resistor frame arrangement should take into repairing conveniently and replacement of the resistive element, is conducive to heat dissipation, the channel should not be less than 600 mm, the distance between the resistive element and the walls and floors should be not less than 150 mm.

③ 电阻器应沿着平行于主梁的方向放置,电阻器架应装置牢固,尽量搭接在走台大拉筋上,以减少起重运行时产生的颤动,必要时可在架子上端增加拉板,拉板的一端可焊接到钢结构上。

Resistors should be parallel to the main beam, resistor frame should be installed securely, as far as possible overlapping walking stage, to reduce vibrate when crane operating, if necessary, increase the pulling plate in the upper frame, one end plate can be welded to the steel structure.

④ 引到电阻器的电线或电缆,其垂直部分可布置在电阻器的左侧或右侧,但不得妨碍电阻器的装卸。水平方向的联接线,靠电阻元件近,绝缘层容易烤坏,可以包以石棉绳等耐高温材料,或者将胶皮绝缘层全部剥去,另包以玻璃布等耐高温材料。

Lead to the resistor wire or cable, part of vertically may be arranged on the left or right side of the resistor, without prejudice to the resistor loading and unloading. Connection line in the horizontal direction, nearly resistive element, insulating layer is easy to roast bad, you can pack with asbestos rope and other high temperature materials, or peeled off rubber insulation, and package with high temperature materials such as glass cloth

5. 保护箱和控制箱/ Protection box and the control box

安装前应对保护箱和控制箱内的元件和电气线路作详细检查元件不得有损坏,特别是接触器灭弧罩和辅助触头等。线路绝缘电阻应符合有关规程的要求。检查接触器和断路器的动作是否正常?各种连锁的准确性与可靠性,并把接触器衔铁接触面上的油垢(出厂时涂的防锈油)擦洗干净。检查各时间继电器的动作是否符合产品出厂技术文件要求的整定值。

Before installing should detailed check the control box and electrical wiring components. Electric element can not be damaged, especially contactor arcchute and arc chute. Line insulation resistance should meet the requirements of the relevant procedures. Check the contactors and circuit breaker operation is normal?

Various interlocking accuracy and reliability, and to grease the contactor armature contact surface (factory-painted anti-embroidered oil) cleaned. Check the time relay operation meets the setting value products manufactured technical documentation requirements.

起升控制箱时间继电器的整定值:1S 为 0.6 秒、2SJ 为 0.2 秒、3S 为 0.6 秒、4SJ 为 0.3 秒。

控制箱前面的通道不小于 600 毫米。控制箱应装得牢固可靠,尽量减少在起重机运行中产生的颤动,必要时可增加支撑,屏面与垂直面的偏差不得超过 5 度。

Hoisting control box of time relay's setting value: 1 s is 0.6 second, 2 sj is 0.2 seconds, 3S is 0.6 seconds, 4 sj is 0.3 seconds.

Control box at the front of the channel is not less than 600 mm. Control box should be installed firmly and reliable, and try to reduce the vibration in crane's operation, increase support when necessary, screen with vertical deviation should not exceed 5 degrees.

6、限位开关/Limit switch

限位开关是保证起重机在运行中不出重大设备和人身事故的重要装置,安装前应仔细检查开关是否灵活可靠。安装后应逐个进行调整。大' 小车限位开关与撞尺间的距离应调整合适,过紧将损坏开关,不起保护作用。起升机械两个限位开关应分别调整好,当吊钩达到极限高度时,首先断开重锤式限位开关,而旋转式限位开关可在较高位置时断开,但此时不应超过极限高度。

Limit switch is the important device to ensure the crane does not happen major equipment accident and

personal accident during the operation, should be carefully check whether the switch is flexible and reliable before installation, also the switches should be adjusted one by one after installation. The distance between the crane and trolley limit switch and bump ruler should be adjusted appropriately, the switch will be damaged if too tight, can not make the protection rule. Two limit switch of hoisting machinery should be adjusted respectively, when the hook reached to the limit height, first should disconnect the hammer limit switch, and rotary limit switch could disconnect at higher position, but should not exceed the limited height at this time.

7、大车导电器/Crane conductor

导电滑线的工作表面必须光滑清洁，大车导电器的绝缘子必须完整无缺和没有裂缝并且要牢靠地固定在导电架上。导电器必须紧密地压在导电滑线上，如运行时发生火花即表示接触不良，其原因可能是导电器和导电滑线接触不紧密或工作表面不清洁，或两者兼而有之。

能常为

Conductive sliding surface must be smooth and clean, cart guide electrical insulator must be intact and without cracks and firmly fixed in conductive frame. Guide electrical must close pressure on the conductive slip line, such as the runtime happen spark it indicates that the poor contact, the reason may be that guide appliances and conductive slip line contact is not close or work surface is not clean, or both.

In order to ensure the security, generally control room is device in the cart conductive slip line to the side, if the device must be on the same side, should add fence

8、小车电锻造导电装置/Crane electrical forging conductive device

起重机使用环境温度-25~45°C时，电缆用CFR型船用橡皮绝缘氯丁护套软电缆，最高温度大于50°C，电缆用CEFR型船用乙丙橡皮绝缘耐热氯丁护套软电缆。最低温度低于-25°C时，电缆用YHD型橡皮绝缘耐寒橡套电缆。

The car electrical forging conductive device

Crane using the environment temperature is 25~45°C, the cable with the CFR type Marine soft cable insulation chloroprene rubber sheath, the highest temperature is more than 50°C, cable with CEFR type Marine ethylene-propylene rubber insulation heat resistant chloroprene rubber sheath flexible cable.

Minimum temperature lower than 25°C, the cable using YHD type rubber Hardy cabtyre cable.

因YHD型耐寒电缆目前不生产单芯的，所以需用两芯的或是三芯的代用，代用时一般遵循下列原则。1x16平方毫米用2x2.5平方毫米代，1x10平方毫米用3x2.5平方毫米代，1x16平方毫米用3x4平方毫米代，1x25平方毫米用3x6平方毫米代，1x35平方毫米用3x10平方毫米代。

Because the YHD type cold-proof cable does not currently have single-core, so the two-core or three-core shall be substituted for it, generally following principles as below. Replace 1x16 mm² with 2x2.5 mm², Replace 1x10 mm² with 3x2.5 mm², Replace 1x16 mm² with 3x4 mm², Replace 1x25 mm² with 3x6 mm², Replace 1x35 mm² with 3x10 mm².

安装时应先把电缆理顺，消除扭力，按图纸要求顺次排列在终点夹、电缆滑车和拖动滑车上。将小车推到离开操作室一端的极限位置上，使电缆放开，调整电缆拖车的位置，使每段电缆的长度基本一致并保持一定的驰度，下垂夹角保持120°左右，调整后，用电缆夹板将电缆牢固地固定在终点夹和拖动滑车上。电缆每隔500-700毫米用铁皮编织并夹紧。应保证每根电缆都夹紧，为此，需在电缆夹板上垫上胶皮。然后装上牵引钢丝绳，调整钢丝绳长度，保证运行时由牵引绳受力，最后将电缆的两端分别接到桥架上和小车上的接线盒中。

When install, the cable first should be smoothened to eliminate torque, and as per drawing arrayed

sequentially at the end clip, cable pulley and drag pulley . Push the car to the limit position at the opposite of cab to release the cable. adjust the position of cable trailers, and maintain each suspension cable in basically same length and a certain degree of relaxation, keeping the sagging angle about 120° . after adjustment, the cable shall be firmly fixed by clip on the end clip and drag pulley. Every 500-700 mm cable with metal braid and clamp. We shall ensure that each cable shall be clamped, therefore, need to put rubber pads on the cable splint.

Then loaded up with tow rope and adjust rope length to ensure that the tow rope bear force just run, and finally ends of the cable are respectively connected to the junction box of bridge and trolley

9. 电线和电线管的铺设/ Cable and Conduit laying

①可以用电焊来固定电线管。

②电线管出线端应衬胶皮或木质套管。露天使用的起重机用沥青封口并使管口向下弯。有条件的可将电线管插入设备进线孔内。操纵室的出线孔应开在侧板上，不要在顶部开孔。

③连接电线管采用直管接头。管组间的直管接头应互相交错的分布。室外用起重机的直管接头应用麻屑和溶解的铅丹堵塞缝隙使之密封。

④按图纸规定在电线和电线管末端的接线盒的端子上标以相应的号码以便于安装和修理。

⑤全部电线铺设完毕后，应用兆欧表测量整个电路的绝缘性能，三相绝缘电阻超过规定标准，而各项绝缘的电阻值差不大时才算合格。

⑥弯曲管子时其弯曲半径应不小于管子直径的 5 倍，所有弯曲角度应不小于 90° 。

①Conduit can be fixed by welding.

②Conduit outlet should be installed rubber or wooden casing. If crane outdoor, use asphalt seal nozzle and bend it down. If having suitable condition, the conduit can be guided into the inlet hole of the device. Outlet hole should be opened on the side of operating room, not the top.

③Connector should be straight. the straight connector should be staggered distribution between each conduit group. the gap of straight connector of cranes outdoor should sealed with hards and red lead dissolved.

④As per drawing, label the corresponding number on the terminal end of the wire and conduit in order to facilitate installation and repair.

⑤After all cable installation is completed, use megameter to measure the insulation performance of the entire circuit. that three-phase insulation resistance exceeds the standard and all insulation resistance values are approximate shall be qualified.

⑥ When bending conduit, bending radius should be not less than five times the diameter of the conduit and all the bending angle not less than 90° .

10 安全接地/Safety grounding

①起重机所有带电部分的外壳，均应可靠地接地以免发生意外的触电事故。小车钢轨不是焊接在主梁上时，亦应采取焊接接地，照明变压器应按图纸规定在低压侧接地。

②凡必须在使用地点安装的设备 and 操纵室的接地工作由使用单位负责进行。

③接地线应采用截面不小于 75 平方毫米的镀锌扁铁，10 平方毫米裸铜线或 30 平方毫米镀锌圆钢。操纵室和起重机本体的接地连接采用 4x10 毫米镀锌扁铁，连接处不应少于两处。

④接地线采用电焊固定，或采用设备上的接地螺钉（镀锌），接头处应清除锈渍，并将接地线涂成黑色。

⑤起重机上任何一点到电源中性点间的接线电阻应不大于 4 欧姆。

⑥在起重机上或电源滑线始端应配备熔断器，其可熔片的额定电流应为起重机或供电滑线最大电流的 0.63 倍。

① all the housing of electrical parts of cranes should be securely grounded to avoid electric shock accidents. When the Rail of car is not welded on the main beam, weld and ground. lighting transformers shall be

grounded at the low pressure side as per the drawing.

- ② the using party shall be responsible for the installation of equipment and grounding work of operating room at workplace.
- ③ grounding wire should be galvanized flat iron whose cross-section not less than 75 mm^2 , or 10 mm^2 bare copper wire or 30 mm^2 galvanized circle steel. The grounding connection of cab and the body of crane using $4 \times 10 \text{ mm}$ galvanized flat iron, not less than two connections.
- ④ grounding line shall be fixed by weld or the grounding screw (galvanized), painted in black. The rust stains of joints should be cleaned.
- ⑤ The wiring resistance between any point of crane to the power supply neutral point should not exceed 4 ohms.
- ⑥ The start of the crane or busbar shall be equipped with a fuse whose the rated current should be 0.63 times than the maximum current of crane or busbar.

四、架设/ Fourth: Erection

(一) 注意事项/ Notes

1. 起重机一般说来属于大型设备之列，其自重多为 10-70 吨，因此安装架设工作由专业部门。即安装工程公司负责进行，对厂矿企业中有专业架设工种的，必要时也可以自行安装与架设。
Crane, a kind of large equipment, has 10t-70t deadweight. Its erection should be responsible by professional engineering company. As for the mine industrial enterprise with professional erection team, the installation can be finished on their own when it is necessary.

2. 架设前必须严格地按下列要求（参照 4-1）检查安装质量，并将实际测定的结果记录在“设备档案卡”上。

Before the erection be started, the team must strictly be in accordance with the following requirements (refer to 4-1) to check the installation quality and record the actual measurement results in the “equipment file card”.

①轨道的接头可为直头的，也可以按图 4-1 所示制成 45 度角的斜接头，一般接头的缝隙为 1-2 毫米，在寒冷的地区冬季施工或安装时，气温低于常年使用的气温，且相差在 20 度以上时，应考虑温度缝隙，一般为 4-6 毫米。两条轨道的断头（共 4 处），安设强固的掉轨限制装置（如加焊接档案），防止起重机从两端出轨，发生桥式起重从高空堕毁的严重事故。

Track fittings can without angles, also can be made to a 45 degree angle as shown in image 4-1 diagonal joints. Generally speaking, the joint gap is 1-2mm. But when temperature is less than the operation temperature and in cold location in winter, and the difference is 20 degree or more, the joint cap should be adjusted as 4-6mm. There should be installed a sturdy track limit device (such as welding archive) in the beheading of the two tracks (4 for total), in order to prevent bridge type crane air crash accident occurred because the crane out of the rails at both ends.

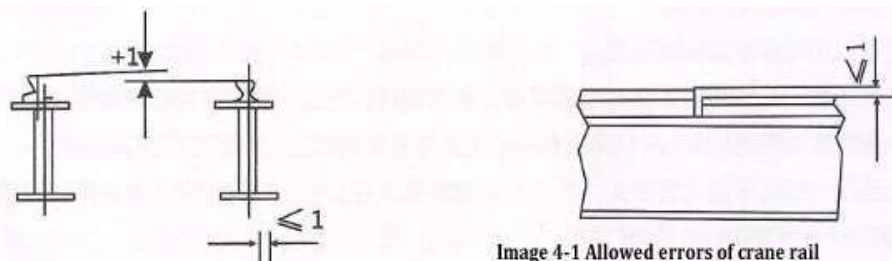

Image 4-1 Allowed errors of crane rail

②接头处两轨道的横向位移或高低不平的误差均不得大于 1 毫米。

The error of the lateral displacement and rough terrain at the joint by two tracks should be less than 1mm.

③两条平行的轨道，在跨度方向的各个同一截面上，轨道的高低误差在柱子处不得超过 10 毫米，在其他处不得超过 15 毫米。

As for the height error of all the same section in span direction for two parallel tracks, should be less than 10mm in the pillar connection point, and be less than 15mm in other places.

④同一侧轨道面，在两根柱子间的标高与相邻柱子间的标高误差不得超过 B/1500 (B 为柱子间距离，单位毫米)，但最大不得超过 10mm

For the tracks on the same side, the height error between every two pillars and the two adjacent pillars should be less than B/1500 (B is the distance between pillars, mm as unit), and the maximum number should not exceed 10mm.

⑤两轨道中心（跨度）轨道中心与承梁中心，轨道不直度误差（如图 4-1）不得超过表 3-1 的规定。

Error of rail angle for the rail between two track centers (span), and for the rail between rail center and rail beam center, should be in accordance with Table 3-1.

Rail mounting tolerance (mm) Table3-1

Span LQ	a	b	c
LQ< 19.5M	3	3	2
LQ>19.5M	5	5	2

3. 架设时

起重机的捆扎，需按第二章第（一）条（4 页）的规定。

3. When installation, the banding of crane need to comply with the regulation of Chapter II (A) Article.

(二) 架示例/ Erection Example

桥式起重机架设时，根据起重设备的能力，可整体架设也可分部架设，整体架设即除操纵室外，将桥架装好，把小车捆牢在桥架上待起升到比操纵室稍高后就将操纵室安装在桥架上，然后一起吊上厂房承轨梁（参见图 4-2）。分部架设即将桥架从端梁连接处拆开，把两根主梁分别架到厂房承梁上，再把小车起升到稍高于主梁，把两主梁靠拢将端梁连接好以后，最后把小车放在主梁轨道上（参见图 4-3）

As per the capacity of lifting equipment, the erection of bridge crane can be divided into the overall erection and divisions erection. the overall erection is that, except the operating room, first, the main girder and end

carriage are assembled together and the trolley should be installed and fastened firmly on the main girder. Second, when the crane are raised slightly higher than the operating room, the cab shall be mounted on the crane. Finally, hang them together onto the bearing beam of plant (see Figure 4-2). Divisions erection is that, first, separate the main girder and end carriage. Second, hang the girders onto the bearing beam of plant, and then assemble the main girders and end carriage together. Third, lift the trolley slightly higher than the girders. Finally, put the trolley on the main beam track (see Figure 4-3).

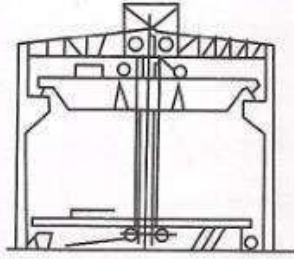

Figure 4-2

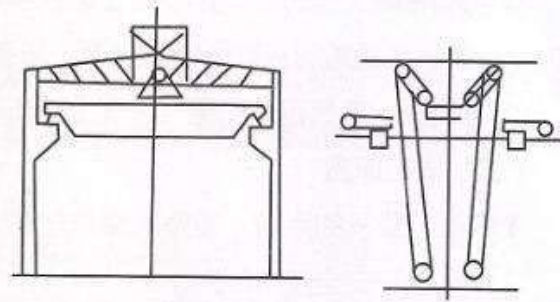

Figure 4-3

五、使用起重机须知/ Fifth: Crane Instructions

(一) 安全技术规则/ Safety Rules

1. 使用起重机必须遵守的安全技术规则

1. Using a crane, safety technical rules must be observed:

(1) 应有专职人员来操作起重机

Should have full-time staff to manipulate the crane.

(2) 起重机的侧面，必须挂上注明起重机的最大起重量、跨度、工作级别、制造厂的标牌。

The crane must hang stated maximum lifting capacity, span, working-level, manufacturer's label on the side of crane.

(3) 起重机工作的时候，除操作室外，其余地方不准站人

When crane works, in addition to operating room, the rest are not allowed to stand on.

(4) 在起重机上进行检测或修理时，起重机必须断电

When test or repair, the power supply must be cut off.

(5) 起重机不带重物运行时，吊钩离地 2.5 米（即超过一个人的高度）。

When the crane run without lifting material, the hook shall be 2.5 m from the ground (more than one person's height).

(6) 严格禁止起重机在搬运重物时，重物从人头上越过。

Strictly prohibit when the crane is carrying the heavy load, the heavy load pass through the person's head.

(7) 起重机带重物运行时，重物最低点离重物运行线路上的最高障碍物至少 0.5 米。

Carrying the heavy load, the lowest point of the heavy load is far away at least 0.5 meters from the

highest obstacle which are running on the line.

(8)严格禁止用吊钩运送或起升人员。

Strictly prohibit the use of the hook transport or lift the person.

(9)禁止用任何方法从起重机上抛下物品。

It is prohibited that thrown the object from crane with any means.

(10)工具、备品、紧固件、杂物等必须贮放在专门的箱子内，禁止随便散放在起重机上，以避免物件落下时发生人身或损坏设备事故。

It must be in a special box such as tools, spare part stock, fasteners, sundries etc. Prohibit scatter on the crane casually in order to avoid personal accidents or damage to equipment when the objects fall.

(11)起升液态金属、有害液体及重要物品时，不论重量多少，必须先稍微起升重物离地 150-200 毫米，验证制动器的可靠性以后再正常起升工作。

When the liquid metal, Noxious Liquids and important items are lifted, we must firstly keep the item 150-200mm height from the ground, and verify the reliability of the brake, then go for normal lifting no matter how much weight the item is.

(12)禁止将易燃物品（如煤油等）贮放在起重机上，做好起重机上的防火工作。

Prohibit to put combustible products (such as kerosene etc.) on the crane, work well the fire prevention on the crane.

(13)露天使用的起重机，当风力大于六级时应停止工作。

It is must to be stop working when the wind is higher than 6 for the crane outside.

(14)露天起重机不工作时，必须设法将起重机可靠固定（例吊钩挂上地锚、车轮处塞斜铁等），以防起重机被风刮走发生意外事故。

It must be tried to put the crane fixed reliable (eg. The hook hang up the anchor, the wheel fill in the angle iron, etc.) in case the crane blew off by the wind to cause an accident.

(15)必须对起重机进行定期的安全检查，其中包括用试验荷重对起重机进行静负荷和动负荷的试验，将结果存入设备档案。

It have to conduct safety inspection regular, including the static load and dynamic load test for the crane with testing load, then put the result into the file.

2.电气设备检修安全技术规则:

Electrical equipment overhaul safety technical regulations:

(1) 只许专职的电气人员担任起重机电气的维修工作。

Only the professional electrical personnel take charge of maintenance work.

(2) 修理时，必须采用电压在 36 伏以下的携带式照明灯。

Have to adopt portable lighting under 36 V of voltage when it to be repaired.

(3) 当须带电工作时，一定要带上橡胶手套，穿上橡胶靴并使用有绝缘手柄的工具，应有专人监护电器开关，一旦发生危险时应立即切断电源，所有靠近导电部分的地方都必须用栅栏围起来。

Ensure to wear rubber gloves, wear rubber boots and use handle tools when the work should be charged, at the same time should have someone monitoring the electrical switch, once being in the danger, he should be cut off the power supply immediately, moreover all conductive parts must be fenced in.

(4) 电动机，电气设备和电气外壳上的所有金属部分可能发生导电的地方必须接地。

Motor, electrical equipment and all metal parts that there is a possibility to be conductive must be grounded.

(二) 司机职责

Driver responsibilities

-
1. 熟悉起重机的用途，设备、操作方法以及保养规则。
Familiar with the use of the crane, equipment , operation and maintenance rules.
 2. 严格遵守安全技术规则。
Strictly follow the rule of security technology.
 3. 起重机开始操作前应做到:
Should be done before the operation of crane:
 - a. 了解电源供电情况，电源电压（大车导电器间电压）低于额定值的 90%时不应开动起重机。
Know the situation of power supply, it should not start to work when the power voltage (conductor voltage of cart) at less than 90% of the rating
 - b. 在总刀开关断开的情况下进行起重机的检视工作，检查主要部分的联接和使用情况，对个别机构进行必要调整。
Please check the main part of the connection and usage y make necessary adjustment about individual mechanism when the total switch cut off.
 - c. 检查起重机上是否遗留工具或其它物品，以免在工作时落下，发生人身或损坏设备事故。
Please check the crane whether leave tool or any other material in order to avoid personal accidents or damage to equipment when the objects fall.
 - d. 按规定对设备的各润滑点加油。
Refuel to the equipment according to regulation.
 - e. 对露天工作地起重机，不使用时应妥善作防风措施。
Do anti-wind measures when does not use for the crane outside.
 4. 在主开关接电之前，司机必须将所有控制器手柄转至零位，并将端梁门关好，起重机工作时，严禁桥架和大车轨道上有人。
Before the switch power, the driver have to turn all controller handles to zero and close the door of end beam. Prohibit someone on the bridge and railway of cart when the crane work.
 5. 起重机在每次开动前，必须发出开车警告（电铃）。
Must be send out the warning(bell) before the crane run every time.
 6. 必须注意被吊起的重物，不得超过额定起重量
The weight of lifting materials must be not exceeding crane related capacity.
 7. 司机必须与挂钩工紧密配合，步调一致，移动和起升重物，只应听从挂钩工所发出的信号，但“停车”信号不论由谁发出，均应立即停车
The driver must follow and be consistent with the hook workers to lift and move materials. But both of them should stop the operation when the stop signal has been sent out.
 8. 吊起重物时，必须在垂直的位置，不允许利用移动大车及小车来拖动重物。
It must be in the vertical position when it is lifting and moving the crane or trolley to drag materials is not allowed.
 9. 起重机及小车接近边缘位置时必须以最缓慢的行速，在不碰撞挡驾的条件下，逐步靠近
It must be adopted the slowest speed and without touching collision when the crane or trolley are toward the edge location.
 10. 起重机的控制器应逐级开动，在机械完全停止运转前，禁止将控制器从顺转位置直接反到逆转位置来进行制动，但在防止事故发生的情况下可以偶尔用来作为紧急措施，但控制器只能打在反向一档之后必须检查确定机械部件没有损伤的情况下能继续作。
Crane controller should be started step by step. It is prohibited to back the controller to the reverse position to brake before the machine stop completely, although this action can be an emergency operation occasionally to protect from accident, the controller can be operated only be first gear in reverse after checking if the mechanical components are without the damage.
 11. 司机要保证防止与另一起重机相撞，在一台起重机发生故障的情况下，才能允许用相邻另一台起

重机来推动这一台起重机，在这种情况下两台起重机须无负荷，而且用最低的速度缓慢的移动。

The driver must prevent the crane collided with another. The crane can be used to move the adjacent crane only when it is failed to move, but both of them must be move with no load with the slowest speed.

12. 在电压显著降低和电力输送中断的情况下，主刀必须断开，并将所有的控制器拉到零位上。

The main brake should be turn off immediately and all controllers should be pull back to empty grade when the voltage gets lower obviously or electricity be interrupted

13. 起重机的电动机突然停电或线路电压下降剧烈时，应将所有控制器拉到零位，司机室内总开关必须马上切断。司机立即以信号通知挂钩工。

All controllers should be pull back to empty grade and the driver should switch off the control switch in the cabin room meanwhile inform the hook worker by signal when the motor blackout or voltage drop sharply.

14. 起重机吊有重物和下放吊具时，司机不得离开操控室。

The driver should keep stay in the cabin when the crane is operated to up and down with material.

15. 当起重机工作完毕以后，吊具应升到上面的位置，使控制器处在零位，并断开主刀开关。

After finished operation to crane, the sling should be stay up and the controllers should be empty grade, and the control switch should be turn off.

16. 工作完毕后司机必须拉开总刀开关和断开电锁。

After finished his work, the driver should turn off the general switch and switch off the electricity lock.

17. 每班工作完成后清扫和擦拭起重设备，再一次检查各部分情况为下一班作好必要的准备工作。

After finished their daily work, the squad should clean the crane and check the part to make sure it can work for next shift.

18. 交接班时，当班司机将起重机交接记录本一并交给当班司机，并将起重操作中所发现的毛病，报告有关部门及接班司机。

When the duty turns, the driver should take over the crane notebook and the questions occurred during the operation to the next shift driver and related department.

19. 司机在离开起重机时，起重机必须停放在规定的停车点并固定好。

The crane should be halt in the parking spot and be fixed well when the driver left the crane.

六、维修与故障的处理/Sixth: Maintenance and fault handling

通用零部件另有专册，这里只介绍桥架，大，小车运行机构，起升机构及电气部分。

Universal Parts in the separate booklet, here only bridge, crane and trolley traveling mechanism, lifting mechanism and electrical parts.

(一) 桥架及其主要构件/bridge and its main component

起重机的桥梁及其它主要金属结构至少每年进行一次全面检查。

Bridges and other major metal structure of the crane at least annually conduct a comprehensive inspection.

1. 检查所有连接螺栓，特别是对端梁接头，主梁与端梁连接，斜梯连接，大车导电维修平台，导电支架及零件，小车架或其它件的连接螺栓就应十分注意，不得有任何松动。

Check all bolts, especially for the end of the beam joints, the connection of end beam and main beam, connection of inclined ladders, crane conducting maintenance platform, conductive frame and parts, trolley frame, or other parts of the connecting bolts should be paid much attention, without any loosening.

2. 检查主要焊缝，宜先用煤油清洗后检查，如发现焊缝有裂纹，应铲除干净，然后用优质焊条焊接，保证焊接质量。

Check the main welds, suggest that after using kerosene, inspect.if found weld cracks, should be removed clean, and then use high-quality welding rod, ensure the welding quality.

3. 检查主梁的上拱度及其它主要件的变形，主梁的上拱度，应按如下方法进行判断，即在无负荷下，

小车开至端梁极限位置，主梁在水平线以下的下沉值（由原始高度向下产生的永久变形，称下沉 F'，当 F' > LQ/2000 时，建议进行修理，各种跨度允许的水平线以下的下沉值列于下表。

Check the deformation of arch of the main beam and other major parts. the judgment should be carried out as follows, that under no load, the car run to the beam end limit position below the horizontal main beam subsidence (the permanent deformation coming out of the downward original height, said the sinking F'), when F' > LQ / 2000, it is recommended to repair. The subsidence below the horizontal which are allowed under a variety of span, are shown in the following table.

跨度/Span	10.5	13.5	16.5	19.5	22.5	25.5	28.5	31.5
下沉值 F' (最大)mm /NO. Subside F' (Max)mm	5	7	8	10	11	13	14	16

(二) 起重机的大小车运行机构/The crane travel and cross travel mechanism

1. 大桥运行机构，桥架歪斜运行，啃咬

Crane long travel mechanism: Bridge structure crooked travel and disharmony contact between the wheel and rail.

①两主动车轮直径误差过大，测量加工更换车轮；

Measure, reproduce, and change wheel to reduce the diameter error of two driven wheels.

②主动车轮不是全部和轨道接触。调整轨道，调整车轮；

Adjust the rail and wheel to make sure every contact surface of driven wheel with rail is normal.

③车轮水平偏斜超差。检查和消除车轮水平偏斜超差现象；

Check and correct the over-error of wheel deflection on horizontal.

④金属结构变形，矫正；

Correct the distorted metal structure.

⑤轨距侧向直线度两轨高低差等。调整轨道，使轨道符合安装技术条件；

Adjust the rail to correct the error of rail gauge, lateral straightness, height difference between two tracks according to the standard demands of rail installation.

⑥轨顶有油污或冰霜。除油污和冰霜；

Clean the grease and frost on the rail top.

2. 小车运行机构打滑，启动时车身扭摆

Trolley travel mechanism skid and shake when it is started.

①轨顶有油污等，清除；

Clean the grease on the rail top.

②轮压不均。调整轮压；

Balance the wheels load pressure.

③同一界面内两轨道标高差过大。调整轨道至符合技术条件；

Correct the elevation difference of two tracks in the same interface according to the standard demands of rail installation.

④启、制动过于猛烈。改善电动机启动方法，选用绕线式电动机；

Improve starting method of motor or choose wound-rotor motor to avoid the hard start and break.

⑤小车轮压不均匀或者主动轮有一只悬空。调整小车三条腿现象；

Balance the trolley wheel load pressure and check if there is one pending driven wheel.

⑥啃轨，解决啃轨；

Correct disharmony contact between the rail and wheel.

(三) 起重机的起升机构/Crane lifting mechanism

1. 选择钢丝绳

Choose right steel wire rope

①断股。打结停止使用；

Knot to stop using if its unit broken.

②断丝。按标准更换；

Change according to standard demand if its wire broken.

③磨损。按标准更换；

Change according to standard demand if it gets worn.

2. 制动器/Brake

①拉杆上有疲劳裂纹，制动器失灵。更换；

If there are fatigue crack on tie rod or unserviceable brake, change them.

②弹簧上有疲劳裂纹，制动器失灵。更换；

If there are fatigue crack on spring or unserviceable brake, change them.

③小轴，心轴磨损量达到公称直径的 3%-5%。抱不住闸。更换

If the abrasion loss of small shaft and spindle has been up to 3%-5% of the nominal diameter and fail to brake, change them.

④制动轮磨损量达原轮缘厚度的 40%-50%，吊重下滑或溜车。更换

If the abrasion loss of brake wheel has been up to 40%-50% of what it was and caused fall or slide, change them.

⑤制动瓦摩擦片磨损达 2mm 或者达原厚度 50%，制动器失灵。更换摩擦片

If the abrasion loss of friction plate on brake block has been up to 2mm or 50% of what it was or unserviceable brake, change it.

⑥不能闸住制动轮，杠杆的铰链被卡住。排除卡住故障，润滑；

制动轮和摩擦片上有油污。清洗油污；电磁铁鑫没有足够的行程。调整制动器；制动轮和摩擦片上有严重磨损。更换摩擦片；主弹簧松动和损坏。更换主弹簧或锁紧螺母；锁紧螺母松动、拉杆松动。紧固锁紧螺母；液压推杆制动器叶轮旋转不灵。检修推动机构电气部分；

Can not brake crane wheel, lever hinge stuck. Exclude stuck fault, lubrication;

There is oil on the wheel and brake lining. Clean oil; electromagnet did not have enough travel. Adjust the brake; severe wear on the brake wheel and friction plate. Replace friction plate; main spring loose and damage. Replace the main spring or lock nut; the lock nut and trolley loose. Tighten the nut; hydraulic push rod brake impeller rotation is not working. overhaul the electrical part of driving system;

⑦制动器不松闸，电磁铁线圈烧毁。更换；

通往电磁铁导线断开。接好线；摩擦片粘连在制动器上。用煤油清洗；活动铰被卡住。消除卡住现象、润滑；主弹簧力过大或配置太重。调整主弹簧力；制动器顶杆弯曲，推不动电磁铁。顶杆调直或更换；油液使用不当。按工作环境温度更换油液；电压低于额定电压 85%,电磁铁吸合力不足。查明电压原因，排除故障

Brake does not release, the solenoid coil burnt. replace;

Disconnect the wires leading to the electromagnet. Connect the line; friction plate sticking to the brake .

Kerosene cleaning; living hinge got stuck. lubricate to eliminate the stuck ; the main spring force is too large or too heavy configuration. Adjust the main spring force; Brake top rod bending, electromagnet not move. Top rod straightening or replacement; improper use of oil fluid . change oil fluid according to the ambient temperature; voltage lower than 85% of the rated voltage, Electromagnet suction force is insufficient.

Identification of voltage reasons, troubleshooting

⑧制动器发热，摩擦片发出焦味并且磨损很快，闸瓦没有和制动器完全脱开。调整间隙；短行程制动器辅助弹簧损坏或者弯曲。更换辅助弹簧；制动轮工作表面粗糙。按要求车削制动轮表面；

Brake heat, friction plate issued a burnt smell and wear out quickly , and brake shoe and brake fully

disengaged. Adjusting the gap; a short-stroke auxiliary spring of brake damaged or bent. Replace auxiliary spring; brake wheel working surface is rough. Turning the surface of brake wheel as per the required;

⑨电磁铁发热或有响声，主弹簧力过大。调整至适合大小；

杠杆系统被卡住。消除卡住的原因、润滑；衔铁与铁芯贴合位置不确定。刮平贴合面。

Electromagnet heat or sound, the main spring force is too large. Adjust to fit the size; Lever system got stuck. eliminate the stuck reason and lubricate; the armature and the core bonding position uncertain. Calibrating the bonding surface.

3. 联轴器/Coupling

①联轴器内有裂纹，联轴器损坏。更换；

Cracks within the coupling, the coupling is damaged. replace;

②连接螺栓有松动，起制动时产生冲击与震动、螺栓剪断、起升机构中则易发生吊重坠落。拧紧。

Connecting bolts loose, resulting in shock and vibration from the start and brake, shear bolts, lifting material are prone to fall. Tighten.

③齿形联轴器齿轮磨损与折断，缺少润滑、工作繁忙、打反车所致联轴器损坏。对起升机构，轮齿磨损达原厚度 15%即应更换。对运行机构轮齿磨损达原厚度 30%即应更换。

Gear of gear couplings wear and break, lack of lubrication, heavy working duty, playing the anti-car result in the damage of coupling. As to the lifting mechanism, tooth wear up to 15% of the original thickness should be replaced. As to running mechanism, tooth wear up to 30% of the original thickness should be replaced.

④键槽压溃与变形，脱键、不能传递扭矩。对起升机构应更换，对其他机构修复使用；

Keyway crushing and deformation, off key, and can not transmit torque. For hoisting mechanism they should be replaced, for other mechanism, they should be repaired;

⑤销轴、柱销、橡皮圈等磨损，启、制动时发生强烈的冲击与震动。更换已磨损件。

Axis pin, pins, rubber bands and other wear, there are a strong shock and vibration when start and brake. Replace the worn parts.

4. 滚动轴承/Rolling bearing

①温度过高，润滑油污垢，完全缺油。清除污垢，更换轴承，按规定加注润滑油。

Temperature is too high, the lubricating oil dirt, completely starving. Remove dirt, replace the bearing, and according to regulations, add oil.

②金属研磨声响，缺油。加油；

Metal grinding sound, lack of oil. add oil;

③齿声或冲击声，轴承保持架、滚动体损坏。更换轴承；

Tooth sound or impact sound, bearing cage, rolling body damage. Replace the bearings;

5. 滑动轴承/Sliding bearing

①过度发热，轴承偏斜或压得过紧。消除偏斜，合理紧固；

间隙不当。调整间隙；

润滑剂不足。加润滑油；

润滑剂质量不合格，换合格的润滑油。

Excessive heat, bearing deflection or overextended. Eliminate the skew, fastened reasonably;

Improper clearance. Adjust the gap;

Lack of lubricant. Add oil;

Lubricants is inferior quality. Change into qualified lubricant.

6. 安全开关失灵/Safety switch failure

安全开关失灵多是由于开关内部构件的卡滞或移动所造成的，在调整和使用中应注意以下几点：

Safety switch failure mostly caused by the clamping stagnation or movement of switch internal structure, the following points should be paid attention during the adjustment and using:

1. 上升极限安全开关要严格按照起升限位开关附加图安装。
Installation of rising limit safety switch should be strictly according to Lifting Limit Switch additional graphs.
2. 每更换或串动钢丝绳后, 均应重新调整安全开关。
After wire rope every changing or string action, the safety switch should be readjusted.
3. 每个班次的开始都应试用一下, 以检查开动开关的可靠性。
It should try to use at the beginning of every shift, this is for checking the reliability of the start switch.
4. 司机不得依靠安全开关的断电动作来代替自己的正常操作。
Driver should not rely on the safety switch power action instead of their normal operation.

(四) 抓斗机构维护和保养/Grab mechanism maintenance

抓斗升降时应同时操纵两个主控器, 注意主控器的每一档位置都要相互对准, 否则应设法调它, 闭合紧斗时, 单独操纵抓斗开闭主控器、卸开抓斗时可以操纵任意一个主控器。抓斗机构采用强力下降, 正常使用时应将主控器手柄推至第六档, 在切除全部启动电阻下运转。检修抓斗时, 如果需要慢速下降或作调整性移动时(下降方向)可将主控手柄推至上升第一档, 使电机处于反接制动下降, 其下降速度的调整可以加减转子总电阻得到它。安装时调整, 抓斗机构两台电动机的每段调速电阻, 相等或相接近, 固定接入电阻(包括联结线电阻在内)应尽可能保持相等。

Should simultaneously operate two master controllers when the grab bucket rising and falling, pay attention to every shift position of the master should be aligned with each other, or we should try to adjust it. When the grab bucket tightly closed, open and close the master controller when alone to control the grab bucket, could control any one of the master controller when remove the grab. Grab mechanism adopts puissant drop, the master controller handle pushed to Sixth gear under normal use conditions, operated in the removal of all starting resistance. When servicing grab, if need slow down or adjustment of moving(down direction) can master controller handle pushed to rise to First gear, make the motor reversed connect braking falling, the falling speed adjustment could add and subtract the rotor total resistance to get it. Adjust when installation, every period speed resistance of grab two motors, should equal or close, fixed access resistance(including connecting wire resistance) should be kept the same as possible.

(五) 电磁起重机、点磁盘维护/Electromagnetic crane and electromagnetic chuck maintenance

1. 点磁盘供电电缆应随吊钩同步升降, 并使保持一弛度, 防止在运行时与任何物件相缠绕的可能性。
Electromagnetic chuck power cable should be synchronized lifting and falling with the hook, and maintaining a degree of relaxation, to prevent the possibility of winding with any object when operation.
2. 经常注意点磁盘放电后与直流控制屏相连接的情况是否正常。
Often pay attention to the connection of electromagnetic chuck after discharge and DC control panel.
3. 用磁场变阻器调整发电机工作电压接近 230 伏。
Using magnetic field rheostat adjust electric generator working voltage close to 230 volts.

(六) 电气设备/Electrical equipment

1. 电气检修制度/ Electrical maintenance system

各种检修期的规定按起重机的工作及环境条件而定。以下所列各种检修制度系指一般情况而言。

The regulation of various maintenance period is according to crane working and environmental conditions. The following listed various maintenance system refers to the general case.

日检修---由起重机每日交接班时进行。检修范围如下清除电气设备外部的灰尘、污泥及油类等附

着物。用手探测电动机，电磁铁，控制器接头，电阻器等发热情况，检查轴承有无漏油现象，主要设备的电线接头是否紧密，在打开观察孔盖或外壳时，应防止灰尘，铁屑等侵入线包内部。将观察所得各种特殊情况记录下来。

Daily maintenance-----Processed by crane daily shifting of duty. Maintenance range is as follows: remove dust, oil sludge or other attachment from the outside of electrical equipment. Detect the heating condition of motor, electromagnet, controller connector, resistors with hand, and check whether the bearing has oil leakage and whether the main equipment wire is tight. When open handhole cover or shell, should prevent dust, scrap iron and other material invade wire bag inside. The observed various special cases should be recorded.

旬日检修（或双周检查）----由电气工作人员执行，司机也需要参加，检修范围如下：清除各电气设备内部的灰尘，污泥等附着物。观察电动机的刷架，炭刷滑环等磨损情况，电动机，电磁铁，继电器及电磁开关等在运行时所发出的音响是否正常，检查并修理控制器与开关的触头。

Ten-day inspection(or two weeks inspection)-----Performed by electrical workers, drivers also need to participate, maintenance scope is as follows:
Clear dust, oil sludge or other attachment from the inside of electrical equipment. Observe the motor brush frame, carbon brush slip ring wear condition, and whether the motor, electromagnet, relays and electromagnetic switch have the unnormal sounds at run time, also check and repair the contacts of the controller and switch.

年检修或大修由电气工作人员执行，检修范围如下：

Annual inspection or overhaul is executed by electrical personnel, maintenance range is as follows:

拆开各项电气设备进行清理，检修各项设备的支架，洗净电动机的滚动轴承并另换新润滑油脂，测量定子与转子间空隙，如发现不均匀时需要更换滚动轴承。测量绝缘电阻，必要时进行干燥。各种毛病在年休时应全部修好，无法修理的部件应该更换，年修或大修范围均有各项设备实际磨损与陈旧程度来决定。

Disassemble all the electrical equipment cleaning, maintenance all the equipment support, wash the rolling bearing grease of the motor and change new lubricating grease, measuring the gap between the stator and the rotor, need to replace the rolling bearing if found uneven. Measuring insulation resistance, if necessary, make it dried. All problems should be repaired at annual inspection, unserviceable parts should be replaced, there will always be actual wear and staleness degree of all equipments to decide within annual inspection or overhaul.

在起重机上必须备有而且只允许用干式灭火器，最常用的为四氯化碳灭火器，不允许使用泡沫灭火器。干沙只能用来扑灭导线的着火，而不能用来扑灭电动机的着火。

On the crane, it must be equipped with and only allowed with dry fire extinguisher, the most commonly used model is carbon tetrachloride fire extinguisher, not allowed to use foam fire extinguisher. Dry sand only can be used to extinguish the wire ignition, cannot extinguish the motor ignition.

当发生火灾时，首先应该设法切断电源，此时用紧急开关或保护盘上的刀闸开关来切断电源。当保护盘前面的导线着火时，应切断馈电线上的刀闸开关。

When a fire occurs, first you should try to cut off the power supply, at this time using emergency switch or knife-switch on protective panel to cut off power supply. When the wire in front of protective panel is on fire, should be cut off the knife switch on the wire.

着过火的起重机要经过清擦，干燥与检查所有电气设备及电气布线，修复合格以后才能再用。

The crane which has fired must be wiping, drying and checking all electrical equipment and electrical wiring, after repair qualified only can be used again.

2. 故障处理/ Fault handling

1. 操纵线路故障

故障情况		发生故障的原因	清除故障的方法
1	合上保护盘上的刀闸开关时，操作电路的熔断器烧断	操作电路 h 中有一相接地	清除接地现象
2	当主接触器合上后引入线上的熔断器烧断	该相接地	清除接地现象
3	当控制器转动后，电流继电器动作	1. 过电流继电器的整定值不符 2. 机械部分某一环节卡住	1. 调整继电器的电流使其为电动机额定电流的 225-250% 2. 检查机械部分
4	电动机不能发出额定功率旋转缓慢	1. 制动器未完全松开 2. 线路中的电压下降 3. 电阻器接线有错	1. 检查并调整制动器机构 2. 消除引起电压下降值超过标准的原因 3. 改正电阻器接线
5	当终点开关的杠杆动作时相应的电动机不断电	1. 终点开关的电路发生短路现象 2. 接至控制器的导线次序错乱	1. 检查引至终点开关的导线 2. 检查接线
6	电源切断后接触器不掉下	1. 操作电路中接地或短路 2. 接触器触头焊住 3. 衔铁接触面油污粘住	1. 用兆欧找出损坏处，然后予以处理 2. 消除接触器被焊住的故障 3. 清除接触面油污

1. Control circuit fault

Fault situations		Causes of the fault	Fault clearance method
1	Operation circuit fuse burn out when close knife-switch of protecting plate	There is a phase ground during the operating h circuits	Clear grounding phenomenon
2	Leading-in wire fuse burn out when the main contactor close	This phase grounds connection	Clear grounding phenomenon
3	When the controller is rotated, the current relay action	1. The setting value of over current relay discrepancy 2. A link of mechanical part get stuck	1. Adjust the relay current and make it to 225-250% of motor rated current 2. Check the mechanical part
4	The motor can not make rated power, rotates slowly	1. The brake is not fully loosen 2. The voltage of circuit drop 3. The resistor wiring is wrong	1. Check and adjust brake mechanism 2. Eliminate the reasons of causing the voltage dropping value exceeds standard value 3. Correct the resistance wiring
5	When the lever of terminal switch action, the	1. The terminal switch circuit has short-circuit phenomenon	1. Check the lead line to the terminal switch

	corresponding motor UPS	2. The wire connected to the controller order disorder	2. Check the wiring
6	Contactors does not fall after cutting off the power	1. Grounding or short circuit during the circuit operation 2. The contactor contact welded 3. Armature contact greasy dirt stick	1. Identify the damage with a Megger then dealt with it 2. Eliminate the contactor fault which are welded 3. Clear the contact surface greasy dirt

2. 交流电机

故障情况		发生故障的原因	清除故障的方法
1	整个电动机均匀的过热	1. 由于工作类型超过了额定值而超载 2. 在低压下工作 3. 电阻器匹配不合适	1. 减少起重机的工作次数或换电动机 2. 当电压降低时，减少其负荷 3. 更换电阻器
2	定子铁心局部过热	铁心的钢片间发生局部短路	消除毛刺或其他引起短路的地方，然后涂以绝缘漆
3	转子温度升高。定子有大电流冲击，电动机在额定负荷时不能到达全速	1. 绕组端头、中性点或并联绕组间的触头不良 2. 绕组与滑环联接不良 3. 电刷器械中接触不良 4. 转子电路中接触不良	1. 检查所有焊接处，消除外部缺陷 2. 检查绕组与滑环的连接处 3. 检查并调整电刷器械 4. 检查连接导线加速接触器或控制器中的转子触头以及启动电阻
4	电动机在工作时振动	1. 电动机轴与减速机轴之间不同心 2. 轴承磨损 3. 转子变形	1. 找正电动机 2. 检查并修理或更换轴承 3. 检查并车圆转子
5	电动机在工作中声音不正常	1. 定子相位错移 2. 定子铁心未压紧 3. 滚动轴承磨损 4. 槽楔膨胀	1. 检查联接线系统 2. 检查定子，重压及重迭定子铁心 3. 更换轴承 4. 锯去胀出的楔子，而缩小者则换新的

2. AC Motor

Fault situations		Causes of the fault	Fault clearance method
1	Entire motor even overheating	1. Overload due to working duty exceeds rated value. 2. Work under low voltage. 3. Resistor does not match.	1. Decrease crane working times or change the motor. 2. When the voltage decreases, reduce the loading. 3. Replace the resistor
2	Stator core local overheating	Local short-circuit occurs between the core steel	Clear the burr or other parts which cause a short circuit, then coated with insulating paint
3	Rotor temperature rises. Stator has a	1. Poor contact of winding ends, neutral or parallel	1. Check all welds, eliminating external defects

	large current shock, the motor could not reach full speed at rated load	winding 2. Poor contact of winding and slip ring connection 3. Poor contact of brush equipment 4. Poor contact of rotor circuit	2. Check the connection of winding and slip ring 3. Check and adjust the brush equipment 4. Check the connection wire acceleration contactor or the rotor contact of the controller and start resistance
4	Motor vibration during operation	1. Misalignment between the motor shaft and reducer shaft 2. Bearing wears 3. Rotor deformation	1. Alignment of the motor 2. Check and repair or replace the bearing 3. Check and drive round the rotor
5	Motor has a unnormal sound when working	1. Stator phase shift error 2. Stator core is not compressed 3. Rolling bearing wears 4. Slot wedge expansion	1. Check the connecting line system 2. Check the stator, great pressure and overlapping stator core 3. Replace the bearing 4. Sawed off expanded slot wedge, should be replaced a new one for shrunken

3. 联动台

故障情况		发生故障的原因	清除故障的方法
1	手柄在工作中产生卡住现象	1. 触头焊住 2. 定位机构发生故障	1. 消除故障修好触头 2. 检查并修理固定销
2	触头烧灼严重	1.触头接触不良 2.控制器过载	1. 调整触头的压力与位置 2. 改变工作规范或更换控制器

3. Linkage platform

Fault situations		Causes of the fault	Fault clearance method
1	Appear stuck phenomenon during pendant panel working	1. Contact terminal welded 2. Positioning system fails	1. Clear the fault, repaired well the contact terminal 2. Check and repair fixed pin
2	Serious contact terminal burning	1.Contact terminal has a poor contact 2.Controller overload	1. Adjust the contact terminal voltage and position 2. Change the work specification or replace the controller

4. 交流制动电磁铁

故障情况		发生故障的原因	清除故障的方法
1	线圈发高热	1. 电磁铁牵引力过载 2. 在工作位置上,电磁铁可动部分与静止部分有间隙	1. 调整弹簧压力或重锤位置 2. 调整制动器的机械部分以消除间隙
2	产生较大的响声	1. 电磁铁过载 2. 磁导体的工作表面脏污 3. 磁导体弯曲	1. 调整弹簧压力或变更重锤 2. 清除磁导体表面的脏污 3. 调整机械部分以消除磁导体弯曲现象

4. AC brake electromagnet

Fault situations		Causes of fault	Solution
1	Coil has a high temperature	1. Electromagnet traction is overload 2. Having gap between electromagnetic movable part and stationary part in the working position	1. Adjusting the spring pressure or the heavy hammer position 2. Adjusting the mechanical part of brake to eliminate the gap
2	Greater noise	1. Electromagnet is overload 2. Magnetic conductor surface is dirty 3. Magnetic conductor is curving	1. Adjusting the spring pressure or the heavy hammer position 2. Clear the dirt in magnetic conductor surface 3. Adjusting the mechanical part to eliminate the curve

5. 交流接触器及继电器

故障情况		发生故障的原因	清除故障的方法
1	线圈发高热	1. 绕圈过载 2. 磁导体的可动部分接触不上静止部分	1. 减少可动触头弹簧的压力 2. 消除引起磁铁可动部分动作不正常的原因（弯曲、卡住、脏污）
2	产生较大的响声	1. 绕圈过载 2. 磁导体的工作表面脏污 3. 磁导体弯曲 4. 磁导体的自动调整系统卡住	1. 减少可动触头弹簧的压力 2. 清除脏污 3. 调整磁导体的位置 4. 消除附加的摩擦
3	动作迟缓	1. 磁导体可动部分离静止部分过远 2. 器械底板的上部较下部凸出	1. 缩短两部分间的距离 2. 垂直装置器械
4	断电时磁铁不掉下	1. 触头的压力不够 2. 衔铁接触面油污过多	1. 增加触头的弹簧压力 2. 消除脏物
5	触头过热或烧焦	1. 可动触头对静止触头的压力太小 2. 触头脏污	1. 调整弹簧压力 2. 消除脏物或更换触头滑块

5. AC contactor and relay

Fault conditions		Cause of fault	Solution
1	Coil has a high temperature	1. Electromagnet traction is overload 2. Having gap between electromagnetic movable part and stationary part in the working position	1. Reducing the pressure of the movable contact spring 2. Eliminating the cause which lead to magnet movable part operate normally(bending, stuck, dirt)
2	Greater noise	1. Electromagnet is overload 2. Magnetic conductor surface is dirty 3. Magnetic conductor bend 4. Magnetic conductor's automatically adjustable system is stuck	1. Reducing the pressure of the movable contact spring 2. Clear the dirt 3. Adjusting the magnetic conductor's position 4. Eliminating the additional friction
3	Operate slowly	1. Magnetic conductor movable part is far away from the stationary part. 2. The instruments base plate's upper part is bulge to lower part	1. Shortening the distance between the two parts 2. Installing the instrument vertically
4	Magnet don't fall off when outage	1. Contact pressure is not enough 2. There are much oil in the armature contact surface	1. Increasing the spring pressure of contact 2. Clearing the dirt
5	Contact is overheating or burning	1. The pressure between movable contact and static contact is too small 2. Contact is dirty	1. Adjusting the spring's pressure 2. Clearing the dirt or replacing the contact slider

七、机构的润滑/ Seventh: Lubrication of Mechanism

起重机设备润滑情况的好坏直接影响起重机各机构的正常运转。同时，与延长机件的寿命和促进安全生产有密切的关系。因此，使用和维修人员必须经常检查各润滑点的润滑情况，按时用油枪通过各润滑点的油杯加油（一般不用涂抹法，因油脂不易进到润滑面上）。

The lubrication condition of crane directly affect the normal operation of mechanism. Meanwhile, it has close relationship with extending part's life and promoting safe production. Therefore, operator and maintenance personnel must always check the lubrication condition of all lubricate point and use oil gun to refuel by the oil cup of all lubricate point.(Generally do not adopt smear method, because the lubrication oil is not easy to immersion the lubrication surface).

(一)起重设备各润滑点的分布/ Distribution of crane's lubrication point

1. 吊钩滑轮轴
2. 固定滑轮轴（小车上）
3. 钢丝绳
4. 各减速器
5. 各齿轮联轴器

6. 各轴承箱（包括车轮组）
7. 电动机轴承
8. 制动器各节点和轴栓
9. 长行程电磁铁（MZS₁型）的活塞部分
10. 电缆导电中滑车的轴承
 1. Hook pulley shaft
 2. Fixed pulley shaft(on trolley frame)
 3. Steel wire rope
 4. Each reducer
 5. Each gear coupling
 6. Each bearing box (including wheel set)
 7. Motor bearing
 8. Each node and shaft bolt of brake
 9. Piston part of long stroke electromagnet (MZS₁)
 10. Bearing of the tackle for conductive cable

(二)润滑条件与润滑材料/ Lubrication condition & Lubrication material

起重设备必须采用合适的润滑油脂。定期润滑和及时更换。润滑装置和各润滑点必须保持清洁。表 7-1 是各机构主要零部件润滑时间的一般规定和推荐用的润滑材料。

Lifting equipment must adopt suitable lubricating grease and is lubricated regularly and changed timely. Lubrication device and all lubrication point must be kept clean. Table 7-1 show the general rules for the main part lubricate time and recommended lubrication material.

表 7-1

序号	零部件	规则	润滑条件	润滑材料
1	钢丝绳	一般 15~30 天一次, 根据实际使用中的润滑情况决定	1. 把润滑脂加温到 80℃~100℃浸涂至饱和为宜 2. 不加热涂抹	1. 钢丝绳麻心脂 (Q/SY1152-65) 2. 涂合成石墨钙基润滑脂 (SYB1405-65)或其它钢丝绳润滑脂
2	减速器	使用初期每季换一次以后可根据油的清洁情况半年~半年换一次	夏季	用 HL30 齿轮油 (SYB1103 - 62)
			冬季 (不低于-20℃)	用 HL20 齿轮油 (SYB1103 - 62)
3	齿轮联轴器	每月一次	1. 工作温度在-20℃~06℃ 2. 高于 50℃ 3. 低于 -20℃	1. 可采用以任何元素为基体的润滑脂, 但不能混合使用。冬季宜用 1、2 号, 夏季宜用 3、4 号 2. 用工业锂基润滑脂 (Q/SY1110-65)冬季用 1 号, 夏季用 2 号 采用 1、2 号特种润滑脂 (Q/SY1119-70)
4	滚动轴承	3~6 个月一次		
5	滑动轴承	酌情		
6	卷筒内齿盘	每大修时加满		
7	电动机	年修或大修	1. 一般电动机 2. H 级绝缘和湿热地带	1. 复合铝基润滑脂 (Q/SY1105 -66) 2. 3 号锂基润滑脂

Table 7-1

No.	Parts	Rules	Lubrication condition	Lubrication material
1	Steel wire rope	According to the lubrication condition in practical use to decide when to lubricate, generally 15-30 days one time	(1)Heating the grease to 80°C -100°C and dip-coating to saturation is advisable (2)No heating daub	(1)Steel wire rope sesame fat(Q/SY1152-65) (2)Coating with Synthetic graphite calcium-based grease(SYB 1405-65)or other steel wire rope grease
2	Reducer	Changing quarterly in initial period. After that, changing once half year-one year according to the cleanliness situation of the oil	Summer	Using HL 30 gear oil(SYB1103 – 62)
			Winter(no lower than -20°C)	Using HL 20 gear oil(SYB1103 – 62)
3	Gear coupling	Once per month	(1)Working temperature -20°C~06°C (2)higher than 50°C (3)lower than - 20°C	(1)Using any element of grease, but not mixed. No. 1,2 is appropriate in Winter and No. 3,4 in Summer. (2)Using industrial lithium grease(Q/SY1110 -65)No. 1 in Winter and No. 2 in Summer. (3)Using No. 1, 2 special grease(Q/S Y1119-70)
4	Rolling bearing	Once per 3-6 months		
5	Sliding bearing	Appropriate		
6	Fluted disc inside the drum	Filling every overhaul		
7	Motor	Annual repair or overhaul	(1)General motor (2)H-class insulation and hot and humid zone	(1)Complex aluminum-based grease(Q/SY1105 -66) (2)No. 3 lithium-based grease

注/Remark:

(1) 表 7—1 中所列 Q/SY 系辽宁省营口市润滑石油脂厂厂标代号，SYB 系石油部部颁标准代号。Listed in Table 7-1, Q/SY is the factory standard code of lubrication oil grease in Yingkou city, Liaoning Province and SYB is Oil Ministry ministerial standard code.

(2) 根据起重机的工作级别（分轻、中、重、超重级等）的不同及工作地区以及场合的条可酌情加或减少规定的润滑时间。表中系按中级工作级别给出的。

According to the work duty(light, medium, heavy, very heavy, etc) of crane and different work areas and occasions, we can add or reduce the stipulated lubrication time appropriately. The table data is based on Medium Grade.

(3) 潮湿地区不宜用钠基润滑脂，因其亲水性强。

Not suitable for use sodium grease in moist areas, because of its strong hydrophilicity.

(4) HL30、20 的产地：东北、华北、华东、青海、甘肃、湖北、四川、新疆、玉门、兰州。

HL30、20 is made in Northeast, North China, East China, Qinghai, Hubei, Sichuan, Xinjiang, Yumen,

经常检查设备的润滑情况和定期给各润滑点加注润滑油脂，是确保设备完好的必要条件之一。

One of necessary conditions to ensure the equipment in good condition is checking equipment's lubrication condition and filling every lubrication point with grease.

经调查，有的单位由于严格地执行这一条件，虽然起重机已经工作了长达 15 年之久，但各机械部件仍然完好无损，至今正常工作。相反也有个别不太注意润滑条件的单位，则出现了如联轴器的齿磨秃，一般一到二年就要更换，严重的甚至用了两个月就磨秃了。结果使电动机与有关机构脱开，造成不堪设想的严重后果。

After investigation, now that some companies enforce this condition strictly, their crane parts are still intact and operate normally after having been working 15 years. On the contrary, there are still some companies not paying attention the lubrication condition, which emerged as the coupling tooth grinding bald. It need to be replaced in one or two years, even be grinding bald in two months. As a result, the motor and relevant mechanism is disengaged which cause serious consequences.

对于钢丝绳、滚动轴承、齿轮等磨损快的主要原因。皆为缺乏必要的润滑所致。它不仅影响了生产的正常进行。同时，也极大的浪费了国家的财富。因此，请各使用单位，特别是司机应认真对待。

The main reason for causing wire rope, rolling bearing, gear wear fast is lack of necessary lubrication. It not only affects the normal production, but also waste nation's wealth greatly. Therefore, every company, especially the driver should take this seriously.

有的油杯打不进油，多因油杯不合格，油杯头的标准锥度为 48 度，过大或过小都会影响加油，油枪头的橡皮易磨损，应经常注意更换。

Some oil cup can't be fed, because of the oil cup unqualified mostly. Oil cup head's standard taper is 48° , too big or too small will affect the feed. Oil spear's rubber wears and tears easily, so we should pay attention to change often.

八、运转实验/ Eighth: Operation experiment

(一)试车前的准备和检查过大或过小都会影响

Preparation before test and inspect too big or too small will all have influence

1. 关闭全部电路，按图纸尺寸及技术要求检查各因接件连接是否牢固，各传动机构装置是否精确灵活。金属结构有否变形。钢丝绳在滑轮和卷筒上的缠绕情况。

Close all circuit and according to drawing dimension and technical requirements to check if every connection is firm, the transmission mechanism is accurate and flexible, metal structure is deformational, the winding condition of wire rope on the pulley and drum.

2. 检查起重机的安装架设是否符合安装架设的有关规定。

Check whether the installation and erection of crane in conformity with the relevant provisions of installation and erection.

3. 电气设备必须在完成下列工作后才能试车。

Electrical equipment must finish the below tasks before test.

(1) 用兆欧计检查电路系统和所有电气设备的绝缘电阻；

Using megohmmeter to check circuit system and all electrical equipment's insulation resistance.

(2) 在断开动力线路的情况下，检验操纵线路接线的正确性，检查所有操纵设备的转动部分是否灵活可靠（必要时进行润滑）。

In the case of disconnected power circuit, test the validity of control circuit wiring, check whether all the rotation parts of control equipment is flexible and reliable(lubricate if necessary).

(3)保证电气设备应工作正常可靠，其中必须特别注意电磁铁、限位开关、安全开关和紧急开关的工作可靠性，注意分别驱动进行机构电动机的接线相序，使两电动机同时运转。

Ensure electrical equipment operate reliably, specially the reliability of electromagnet, limit switch, safety switch and emergency switch. Pay attention to the mechanism of motor separate driven connection phase sequence to make two motors operate simultaneously.

(二) 开负荷试车/No loading test

用手转动各机构的制动轮。使车轮轴或卷筒轴在旋转一周时不得有卡住现象。然后分别空载通电试车、各机构应正常运转。小车支行时，主动轮应在轨道全长上接触，然后分别空载通电试车，各机构应正常运转。小车运行时，主动轮应在轨道全长上接触，检查各限位开关是否安全可靠。

Using manually rotated brake wheel to make the wheel shaft or drum shaft have no stuck in one rotation. Then every mechanism should operate properly when no-loading test. When the car branch, driving wheel should contact the track nad on the track fully and then No-load current test respectively, every mechanism should operate normally. When the car is running, driving wheel should contact the track nad on the track fully to check whether the limit switch is safe and reliable.

(三) 负荷试车/Loading test

无负荷试车情况正常之后，才允许进行负荷试车。负荷试车分静、动两种。先进行静负荷试车。再进行动负荷试车。

Load test is allowed after no load test is normal. Load test has two models: static test and dynamic test. First proceed static test and then proceed the dynamic test.

1. 负荷试车的检验内容/ Testing content of loading test

① 起重机金属机构各连接处的螺栓连接、铆接或焊接的质量。特别是端梁连接处的质量。

Quality for joints of crane metal structure, such as the bolt connection, riveted or welded, especially the quality of the end beam joint.

② 机械设备、金属结构和吊具的强度和刚性以及起重机钢轨的强度。

Mechanical equipment、metal structure and hook strength and rigidity and crane rail strength

③ 制动器应动作灵活，工作可靠，吊钩不得有残余变形、裂纹等缺陷。

Brake should be flexible, reliable, hook shall not have residual deformation, cracks and other defects.

④ 减速器无不正常的噪音（断续噪音或尖叫声）。

Reducer has no unusual noise(intermittent noise or screams)

⑤ 润滑部件的润滑性应良好，轴承温度升高不超过规定的数值。

Lubrication components have good lubricity, bearing temperature rise shall not exceed the specified value

⑥ 各机构部件应平稳，无振动现象。

Agencies parts should be smooth, no vibration phenomenon.

2. 静负荷试车/Static load test

小车起升负荷（逐渐增值额定负荷），在桥架全场往返运行，并检验性能应达到设计要求。卸去负荷，使小车停在桥架中间，定出测量基准点。起升 1.25 倍额定负荷，离地面 100 毫米左右，停悬 10 分钟，然后卸去负荷，检查桥架是否永久变形，最多在三次检查后不再生产永久变形时，将小车开至跨端，检查实际上拱值要大于 0.9L/1000，最后使小车停在桥架中间，起升额定载荷检查主梁挠度值小于 LQ/800(由实际上拱值算起)。

Trolley lifting load(gradually appreciate the rated load),run back and forth along the bridge structure, and test the performance should meet the design requirement. Removal the load, keep the trolley at the middle of bridge, set measurement reference point. Lifting capacity is 1.25 times of rated capacity, 100mm lifting from the ground, hover ten minutes, then remove the load, check if the bridge structure has permanent deformation after a maximum of three checks if no longer permanent deformation, drive the trolley to the end, check the

actual arch value is greater than 0.9L/1000, and finally stop the trolley at the middle of bridge span, rated lifting capacity check the girder deflection value is less than $LQ / 800$ (from actual arch value)

3. 动负荷试车/Dynamic load test:

起升 1.1 倍额定负荷作动负荷试车。同时开动两个机构作反向运转。按工作级级别应有间歇时间，试车时间应延续 1 小时。各机构应动作灵敏，工作平稳可靠，并检查限位开关和保护、联锁装置的可靠性。

Dynamic load test is 1.1time of the load capacity. At the same time to start the two institutions do reverse operation, according to the work duty there should be intermittent time, test time should be continued for one hour. Agencies should be sensitive, stable and reliable, and check the limit switch and the reliability of protection and interlock.

(四) 电磁起重机的试车/Electromagnetic crane commissioning

(1) 电磁起重机的无负荷、静负荷以及动负荷试车规定和以上所规定的完全相同可用它本身吊钩进行负荷试验。

Electromagnetic crane's no load, static load and dynamic load test requirements are completely same as above regulations, the crane itself hook blocks can be used to perform load test.

(2) 电磁盘的控制部分也应做实验，其目的是检查线路的接线正确性和电动机是否正常运转。

Control parts for electromagnetic can also do the experiment, the purpose is to check the correctness of the line connection and whether the motor is running.

(3) 电磁盘的载荷能力，可按电磁盘承制厂的规定进行检验，如无此资料时推荐按下表检验。

Electromagnetic disk load capacity, should conduct tests should according to the regulation of electromagnetic disk factory regulation, we recommend the following table tests if absence of such information.

电磁盘载荷能力表（单位：公斤）

Electromagnetic disk load capacity table (Unit: kg)

电磁盘型号 Electromagnetic model	MW1-6	MW1-16
吸引钢板或钢坯时 Attract steel plate or steel billet	6000	16000
吸引钢板皮时 Attracting steel skin	180	500
吸引生铁锭时 Attract pig iron	200	600
吸引钢屑时 Attracting steel scraps	80	200

(4) MW1-6 电磁盘本身重量为 460 公斤，MW1-16 本身重量为 1670 公斤，试验起重机时应注意电磁盘本身重量要算在额定起重量之内，例如 5 吨电磁起重机用 MW1-6 型电磁盘时，最多只允许吸取 $5000-460=4540$ 公斤的荷重（额定起重量）

MW1-6 electromagnetic disk self weight 460kg, MW1-16 self weight 1670 kg, the electromagnetic self weight should be calculated at rated lifting capacity when test , such as:5 tons electromagnetic crane use MW1-6 type electrical disk, it's allowed to attract $5000-460 = 460$ kg load (rated lifting weight) at most.

(5) 电磁盘有共数据和规定可详见电磁盘承制厂说明书。

Electric disk have common data and regulation, please refer to electromagnetic disk factory specifications.

(五) 抓斗起重机的试车/Grab crane commissioning

(1) 抓斗起重机无负荷、静负荷以及动负荷试车规定除与以上第 2 节到第 3 节所规定的完全相同外，另外补充以下诸条：

Regulations for grab crane commissioning without load, static load and dynamic load is same as above provisions of section 2 and 3, below are the supplementary article:

a、测量所抓物料的容量（或称假比重）及粒度大小、不得超过设计规定值。

Measuring the capacity of the grasped material (or bulk density) and particle size, the value shall not exceed the design requirements.

b、试车时应注意抓斗本身重量算在起重额定起重之内，例如若所用抓斗本身重量为 1200 公斤，则 5 吨抓斗起重机所抓物料的重量不得超过 $5000-1200=3800$ 公斤（额定起重）。

Grab self weight shall be calculated at the rated lifting capacity when commissioning, such as: the grab self weight is 1200kg, the 5ton grab crane grasped weight shall not exceed $5000-1200=3800$ kg.

c、抓斗的无负荷试验和负荷试验应作下列动作每个动作在无负荷时轮流操纵作不少于两次，符合时不应少于五次。

Grab without load test and load test shall be done the following actions, every action during no-load manipulation by turn should not less than twice, at least five times can comply with requirements.

(a). 张开的抓斗下降，开闭卷筒和起升卷筒同时以下降方向旋转、抓斗，一直降到鄂板插进被抓取的物料合为止。

Opened grab fell down, the open/close drum and lifting drum will rotate while lowering, the grab will down to the scraped material that jaw is inserted into.

(b). 抓斗闭合；开闭卷筒依上升方向旋转而起升卷筒则停止不动时，两鄂板逐渐合拢直到它们两边的切割刀口完全密合为止。

Grab closed; open/close drum rotate while rising, and lifting drum doesn't move, two jaws will shut until its cutting edge is completely closed.

(c). 抓斗起升、两个卷筒同时依上升方向旋转。

Grab lift, two drums will rotate while lifting.

(d). 倾倒抓斗中的物料起升卷筒被制动，开闭卷筒依下降方向旋转，抓斗鄂板即因本身重量的作用而张开，物料即被倒出。

Dumping grab material, the lifting drum is braked, open and close drum rotates at falling down direction, grab jaw is opened by the action of its own weight, the material is poured out.

(2) 在试抓斗时应检查/Grab shall be checked while commissioning

a. 主要参数是否符合图纸要求

Whether main parameter can meet the drawing requirement.

b. 各机构的灵活性。

Flexibility of all agencies.

c. 鄂板的闭合是否密合

Whether the jaw is closed completely

(3) 抓斗负荷试验时，应测定所能抓取的物料容积是否符合要求。

When the grab is tested with load, should measure whether the captured material volume can meet requirement.

(4) 用抓斗时应使 4 根钢丝绳都平均受力，否则容易造成断绳事故。

While using grab bucket, the four wire rope shall be stressed average, otherwise it's more likely to cause wire rope broken accidents.

(六) 电器部件试验规定与检查项目/Electrical components test regulations and inspection items

①重机各机构作反复运转的时间应不超过 15 分钟。因此，试验时各机构宜交替运转。只有当机构完全停止后才允许反转。

Crane agencies repeated operation time shall not exceed 15mins. Therefore, agencies should alternately during the test run. it can be allowed reverse only when the body is completely stopped.

②当控制器在不同位置时，检查电动机运转是否正常。

When the controller is at different positions, check whether the motor can operate normally.

③检查各种限位开关、安全保护装置、联锁装置，动作是否正确可靠。

Check whether different limit switches、safety protection device、lock device、action is reliable.

④电气设备运转中的故障应消除，不允许电动机和电气设备的升温超过规定标准。活动节点不得有烧灼的情况。设备不应有不正常的响声和振动等现象。

Failure of electrical equipment operation should be eliminated, heating for motor and electrical device shall not exceed standard requirement. Active node should be burning. The equipment should not have abnormal noise and vibration, etc.

九、起重机的交工验收/Ninth: Crane acceptance

起重设备出厂前，制造厂已根据起重机专业标准“普通桥式起重机技术条件”进行了一系列的质量检查和运转试验（根据设备条件在制造厂作部分机构的试车或整台起重机的试车），检验合格后发给产品合格证明书。

Before the equipment leave factory, the manufacturer shall has finished series of quality inspection and running test(according to the equipment condition in factory to the part mechanism commissioning or entire crane commissioning) in accordance with professional standards" General bridge crane technical conditions", quality certificate shall be issued after the test is qualified.

为了确保起重机在使用单位最后安装，架设的质量符合要求，使用单位在正式使用起重机之前，仍应按第八章的有关规定进行运转试验。

In order to ensure the crane final installation and erection meet the requirement at the user site, the user shall perform test and commissioning according to the regulation by Chapter VIII before using the cranes.

运转试验之后，安装单位与使用单位应办理起重机交工验收手续，交工验收包括：

After running test, the installation unit and user unit shall handle completion of the acceptance procedures, project checking and accepting include:

- 1、起重机试车运转记录单 Crane commissioning operation record sheet
- 2、起重机交工单 Crane timesheets
- 3、起重机投产保证书 Crane production guarantee

起重机试车运转记录单，安装与使用单位应各执一份。如果机器有缺陷，不论是否已被修好，均应登记在记录单内，作为原始依据。

Crane commissioning operation record sheet, Installation and use the unit shall each hold one copy. If the machine is defective, regardless of whether it has been repaired, it shall be registered in the records sheet, as the original basis.

十、附录/Tenth: Appendix

（一）大车跨度测量法/Crane span measurement method

大车跨度可用钢尺测量，但必须考虑钢尺因受拉力所产生的均匀弹性伸长及钢尺因自重产生的下挠。经计算，伸长大于下挠。综合考虑，将测量所得钢尺上的读数加上下表所列的修正值，即为起重机的实际跨度。

Crane span can be measured by ruler, but the homogeneous elastic elongation produced by pulling force and down-warping produced by ruler self weight shall be considered. After calculation, elongation is greater than the down-warping. Overall consideration, the readings obtained on the steel rule listed in the following table together with the correction value is the actual span of the crane.

Steel rule section mm ²		修正值 mm / Corrected value mm			
		10*0.25	13*0.2	15*0.2	15*0.5
Span m	Tension N				
10.5	100	2	2	1	1
13.5		2	2	2	1
16.5		2	2	2	0
19.5		3	2	2	0
22.5	150	6	5	4	2
25.5		6	6	4	2
28.5		7	6	4	2
31.5		7	6	4	1

(二) 主梁拱度测量法/Main girder camber measurement method

主梁拱度可用水平仪或拉钢丝法测量，拉钢丝法是将细钢丝支撑在主梁两个等高的撑杆上，一端固定，加一端用秤砣或弹簧秤拉紧。以钢丝直径为 0.5mm,拉力为 150N 为例、主梁实际拱度应为撑杆高度减去钢丝距上盖板的测量值和下表所列的因钢丝自重下垂和扣除值。

Main girder camber can be measured by gradienter or drawn steel wire, the wire method is support fine steel wire in two main beam high strut, fixed at one end, and end with weight or a spring balance taut. For example wire rope dia. 0.5mm, pull length is 150N, main girder camber shall be the height of poles actual minus the measured value of the steel wire after the cover plate and listed in the table below for the wire weight of prolapse and deducted from the value.

跨度 Span (m)	10.5	13.5	16.5	19.5	22.5	25.5	28.5	31.5
扣除值 Value deducted	1.5	2.5	3.5	4.5	6	8	10	12

注：如在室外，主梁拱度的测量应在早晚，不受日照的影响。

Note: If the crane used outdoor, the main girder camber measurement shall be at morning or evening, won't affected by sunlight.

产品质量反馈建议书

Proposal letter for quality feedback of product

尊敬的用户：

您好！非常感谢您使用我公司提供的产品，我公司生产的起重机产品在各行各业得到广泛应用，为了进一步提高产品质量，更好的为您服务，请您把我公司身缠的起重机产品，在整机性能，安全可靠，耐久性，外观以及服务等方面的宝贵意见和改进建议填入下表。我们将认真听取您的意见，相信在大家的共同努力下，我们会越做越好！再次感谢您对我们工作的理解和支持！

Respected users:

Thank you very much for using our product. The cranes made by our company are widely used in every industry. Please complete the table below with your valuable advices and improvement recommendations involved in the crane made by our company in the field of entire machine performance, safety and reliability,

durability, exterior appearance and service, etc. We will take your opinions to heart. We believe we will have a continued development under our joint efforts! Thanks again for your understanding and supporting to our work!

使用单位 User unit		详细地址 Detailed address	
产品型号 Model of product		产品编号 SN. Of Product	
启用时间 Date of first use		联系人 Contact person	
联系电话 Tel		传真 Fax	
建议 (Advice):			

用户单位：(公章)
User unit: (Official seal)

日期：
Date:

YUGONG