电动门式起重机安装指导维修说明书

Gantry Crane Crane Operation Manual

豫工

YUGONG

Content

One	General instruction.....	2
Two	Crane assembling.....	2
Three	Crane commissioning.....	8
Four	Project acceptance check.....	12
Five	Lubrication.....	14
Six	Operation instructions.....	16
Seven	Maintenance.....	18
Eight	General drawing.....	24
Night	Electrics.....	26

豫工

YUGONG

One General instruction

I. This instruction book applies to crane assembling, commissioning and maintenance of double girder gantry crane and single girder gantry crane.

II. Dimension and technical parameters. (pls check detailed drawing along with the crane.)

III. Application

Gantry cranes is mainly for outdoor use, due to different working conditions, gantry cranes can be equipped with hooks, grab bucket and electro-magnetic.

Temperature: -20°C -- $+40^{\circ}\text{C}$

Altitude: $\leq 2000\text{m}$

Wind speed during crane operation: $\leq S6$

Cranes need to be customized when factor is not covered in above scope.

IV. Checking & Inspection

When crane is delivered to clients' site, clients should check details as per packing list along with the delivery.

Crane assembling

I. Preparation and Attention

1. The technicians should be familiar with delivery documents and technical documents, as per technical requirement, to eliminate tolerance and deformation caused by transportation and improper storage. In case there is structural distortion, adjustment should be made before assembling.
2. During the preparation, check rusting condition and clear rust, even repainting and reassembling. Making sure all rotation mechanism like pulley sheaves, rope drum and wheels rotating normal; bolts firm; bearing with grease.
3. Should keep in mind to avoid twist, bend and hit during crane transportation. Should hang the main girder instead of the maintenance platform during hoisting up the crane.
4. During storage, the crane should be placed on solid ground in case either side lost balance which can cause steel structure deformation. In case the crane is outdoor storage, should prepare to prevent it from sun and corrosion.

II. Inspection before crane assembling

1. Inspection on steel structure

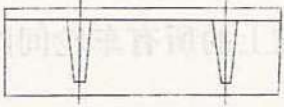
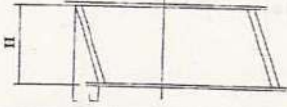
No.	Item	Sketch	Tolerance
1	Span length upper deflection Cantilever upwarp		$E = (0.9 \sim 1.4) / 1000S$ $h = (0.9 \sim 1.4) / 350L_1 (L_2)$
2	Cover plate decline of main girder		$C \leq B/200$
3	Side plate vertical deviation of main girder		$h \leq H/200$

2. Inspection on traveling mechanism (check wheels in condition of above ground)

(1) Wheel vertical deviation

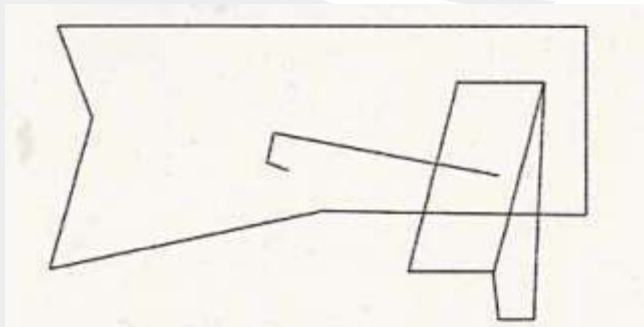

a> Wheel shaft assembled by hole by boring machine

$$tg\Phi \leq \pm 0.0025$$

b> Angle type bearing box

$$A \leq 1/400 \quad L = \text{measurement}$$

(2) Wheel lateral deviation

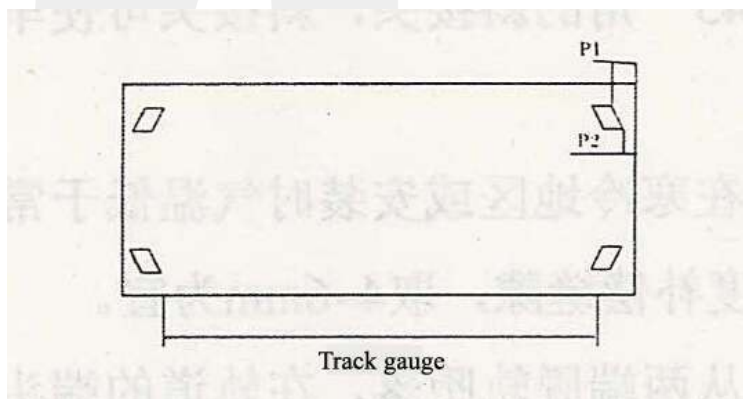

a> Wheel shaft assembled by hole by boring machine

$$\text{tg}\Phi \leq \pm 0.0015$$

$$p_1 - p_2 \leq 1/1000 - 1/1200$$

Two wheels of the same axis deviate at opposite direction.

In case there are more than 4 wheels, clearance between all wheels of the same rails should $\leq 1/1200$.

(3) Wheel idiostatic of the same ground girder should be $\leq 1\text{mm}$; In case there are more than 2 wheels, the wheel idiostatic should be $\leq 3\text{mm}$.

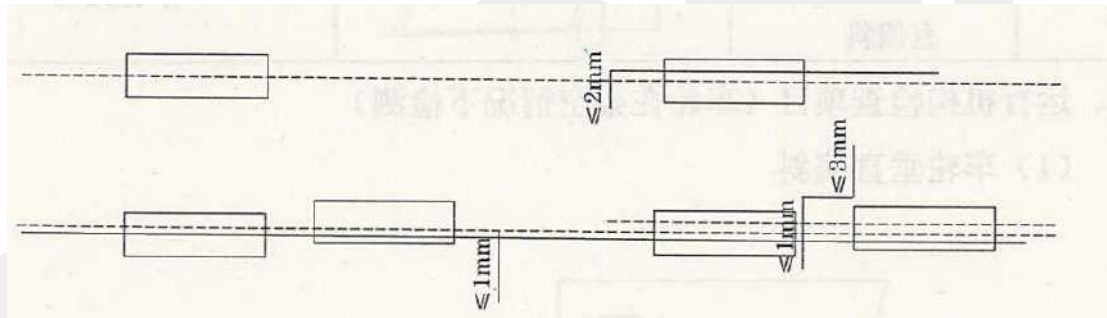

III. Crane assembling

1. Machinery installation

(1) Hoisting equipment is special equipment, crane assembling and commissioning should be by specialized department; while those companies who are approved qualified also are allowed to do the crane assembling and commissioning.

(2) Refer to the crane assembling, it can be either partially assembled or whole set assembled according to the capability of prepared equipment.

(3) Check the rail assembling strict to requirement before crane assembling.

a> Rail end to be connected can be either straight or 45 degree angle; 45 degree angle can enables smoother traveling when wheels pass the rails joint.

b> Gap between rails should be 1—2mm, in case temperature difference is more than 20 degree, temperature compensation gap should taken into consideration, in this condition, 4—6mm is preferred.

c> Rail stopper should be placed at rail end to avoid derail.

d> Refer the crane joint, lateral shearing and height difference of two rails should be $\leq 1\text{mm}$.

e> Refer to rail tracks, height difference of each section should be $\leq 1.5\text{mm}$.

f> Inner span length

① Admissible error of span length should be $\leq \pm 5$.

② Admissible vertical error of rails should be $\leq \pm 2$.

(4) During crane assembling, related technical requirement should be followed.

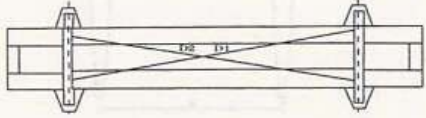
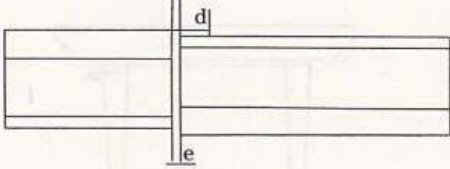
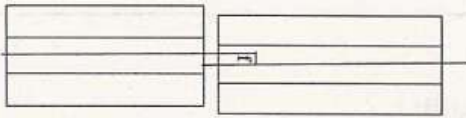
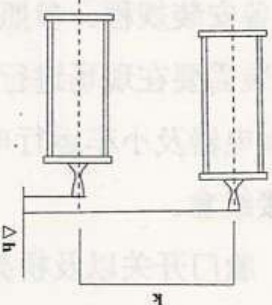
No.	Item	Sketch	Tolerance
1	Diagonal difference of gantry frame D1-D2		$D1-D2 \leq 5\text{mm}$
2	Height difference and joint gap of trolley rails d & t		$d \leq 1\text{mm}$ $e \leq 2\text{mm}$
3	Lateral displacement of rail joint f		$f \leq 1\text{mm}$
4	Height difference of rail gap of same section h		$(1) k \leq 2\text{m}$ $\Delta h \leq 3\text{mm}$ $(2) k \leq 2\text{m}$ $\Delta h \leq 0.0015k$

YUGONG

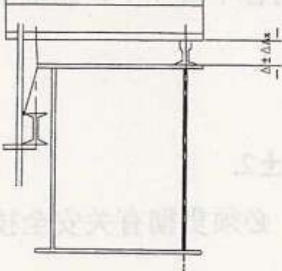
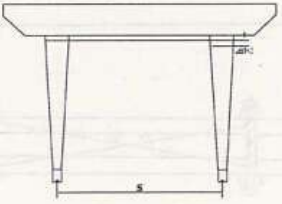
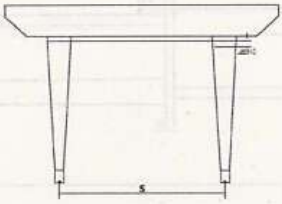
5	Trolley track gauge difference Kx Ax		<p>(1) Double girder $\Delta kx = \pm 2\text{mm}$ (2) Single girder $\Delta kx = \pm 3\text{mm}$ $\Delta Ax = -3\text{mm}$</p>
6	Span S		<p>(1) $S \leq 26$ $\Delta S \leq \pm 8\text{mm}$ 且 $\Delta S1 - \Delta S2 \leq 8\text{mm}$ (2) $S > 26\text{m}$ $\Delta S = \pm 10\text{mm}$ 且 $\Delta S1 - \Delta S2 \leq 8\text{mm}$</p>
7	Height difference between wheel thread and upper flange of legs h		

2. Electrics

- (1) Electrical equipment assembling, adjustment and wiring tube distribution should be as per electrical diagram.
- (2) Following electrical equipment should be assembled at site.
 - a> Conductor of power supply to crane and trolley.
 - b> Control panel, resistor and junction box.
 - c> Crane lighting system.
 - d> Wiring of gantry crane, control panel, protection box.
 - e> Welding of part of the wiring tube.
- (3) Electric equipment like resistor, control panel, Rectifier cabinet can be replaced as per condition requirement of site.
- (4) 22
- (5) There should not be third connection in the middle of all electric cables (transition terminals should be can be used refer to the lighting cable). Safety measure should

be considered in case wiring tube is applied in order to protect the cable from abrasion. Water proof measures should be considered to protect the electric cables in case the crane is outdoor running.

- (6) Water proof measures should be considered when the cables go through wiring duct and wiring tube.
- (7) By both ends of the wire, cold-press terminal stud should be pressed tight to the wire by cold compression pincers.
- (8) Both ends of the wire should be with permanent marks same with that of the diagram.
- (9) In case using angle steel sliding wire, should adjust angle steel making sure contact surface leveled and without rust. If use bare copper wire or security sliding wire, adjust the current collector to make sure it contact the sliding wire even.
- (10) During angle steel sliding wire assembling, horizontal equilibrium error should be $\leq +10\text{mm}$, vertical error should be $\leq +20\text{mm}$.
- (11) When voltage of main circuit and control circuit is $\leq 500\text{V}$, circuit insulation resistance to earth should be ≤ 0.8 .
- (12) Safety measures: In case the voltage is $\geq 500\text{V}$, high voltage power supply regulations should be followed.
- (13) Grounding requirement
 - a> Reliable electrical connection between steel structure.
 - b> In case the crane is running on rails, reliable electrical connection should be between crane wheels and rails.
 - c> When the cabin is bolted to the crane, grounding wire should be flat steel of at least $40 \times 4\text{mm}$ or copper line of at least 12.5mm . Should be at least 2 earth points.
 - d> Connection between earth line and equipment can be bolt type or welded.

Three Crane commissioning

I Visual inspection

1. Preparation and inspection before crane commissioning

- (1) Turn off circuit; confirm whether crane assembling and erection follows the requirement.
- (2) Do inspection on following items:

-
- a> Crane overall dimension
 - b> Steel structure deformation, weld metal cracking.
 - c> Lubrication on lubrication points
 - d> Machine parts completion, all drive system normal.
 - e> Fastener
 - f> Gear connection
 - g> Brakes assembling
 - h> Obstacles which will impede crane running
 - i> Wire rope winding on rope drum and sheaves (no cross over, no tie)
- (3) Check electrical system and insulated resistance
- a> Check electrical system and insulated resistance with Meg Ohm Meter
 - b> Cut off power, check wiring
 - c> Check wiring to the motors

II Commissioning

1. No load test

Check hoisting up/down without load for 3 times, there should not be stuck; start all motors checking whether running normally. Running both crane and trolley along the rails for 3 times, checking whether there is rail gnawing. Driving wheels should touch the rails all along the rail length, gap between driven wheels and rails should be less than 1mm.

2. Load test

(1) Static load test

Hoisting up rated load and running along the main bridge, checking whether the performance confirm to requirement.

Remove the load and run the trolley to the middle of the main bridge, find datum mark and then hoisting 1.25 times of the rated load up to 100-200mm above ground for 10 minutes. Remove the load and check whether there is permanent deformation on the bridge structure. Bridge structure should not have permanent deformation after 3 times load test.

Move the trolley to either end of the bridge and check bridge camber should at least $0.7/1000S$; in case there is cantilever, the cantilever arch up should be at least $0.7/350L1(L2)$.

(2) Dynamic load test

Hoist 1.1 times of the rated load and running the crane. Each mechanism should be

running separately during the commissioning; then start over. Test should last at least 1 hour and make sure every mechanism run normally.

(3) Inspection after the commissioning

① Mechanical

- a. Welding and bolts
- b. Strength and rigidity of mechanical equipment, steel structure hook and rails.
- c. Brake (Timely feedback)
- d. Reducer (No abnormal sound and oil leaks)
- e. Lubrication
- f. Each system running smooth (no abnormal vibration and sound)

② Electrics

- a. Each crane system should be running for test repeatedly, but counteractions can only be done after all system stops.
- b. Check motors operation when controller is in different position.
- c. Check all limit switch, protection device and brakes.
- d. Failure in electrical equipment operation should be eliminated and temperature rise of motors and electrical equipment should not exceed that required by standard.

3. Commissioning of grab crane, electro-magnetic crane and crane with 2 or 3 trolleys. Besides, above mentioned test, following test should be included in the crane commissioning for grab crane, electro-magnetic crane and crane with 2 or 3 trolleys.

(1) Electro-magnetic crane

- ① Should test electric control of the magnetic to make sure correction of the circuit wiring.
- ② During crane commissioning, magnetic self weight should be taken into consideration.

(2) Grab crane

- ① Volume, density and particle size of materials to be grabbed should conform to standard.
- ② During crane commissioning, grab self weight should be taken into consideration.
- ③ Should do following operation to the grab with/without load.
 - a. Down the grab when it's open till the grab into the material to be grabbed.
 - b. Roll the drum which controls the grab close upward, start the drum which controls

the grab up/down when the wire rope get loose, till the grab fully closes.

- c. Check gap between dics when the grab is fully closed.
- d. Wire ropes of the grab should bear equal forces.

(3) Dual purpose crane

Do test on grab, electro-magnetic and hook separately.

(4) Cranes for three purpose

Do test on grab, electro-magnetic and hook separately.

(5) Crane with 2 trolleys

Two trolleys should be close to each other and lift rated load when testing the deflection.

III Quality acceptance

Check following form with test covered in I and II.

No.	Item	Unit	Requirement	Tolerance
1	Tested load	t	Rated load	± 1%
2	Lifting height with load	m	Check in design drawing	± 1.5%
3	Limit position of the hook	m		± 2%
4	Hoisting speed with load	m/min		+10 -5%
5	Down speed with load	m/min		+25 -5%
6	Traverse and traveling speed	m/min		+10 -5%
7	Brake distance when down with load	m		Check item 4.2 no.3
8	Motor rotation reduction when brake with laod	m/min	Check item 4.2 no.4	
9	Deflection of main girder Crane static rigid Deflection of effective cantilever	mm	Check item 4.2 no.8	
10	Crane dynamic rigidity Self-vibration frequency of main girder under load	Hz	Check item 4.2 no.9	
11	Insulation resistance to earth	MΩ	Check item 4.9 no.14	
12	Crane equipment sound	dB (A)	Check item 4.9 no.24	
13	Limit switch reliability	—		

Four Project acceptance check

Ex-factory inspection as per standard requirement of *General Gantry Crane* is required; this includes quality inspection and crane commissioning. Quality certificate is issued only when the ex-factory inspection is approved.

To make sure crane is qualified to be put into work, crane assembling and commissioning at user's site should strictly conform to the requirement.

Once the crane assembling and commissioning is finished and approved, crane installation unit and user should sign on project inspection and acceptance sheet. The documents should cover following:

1. Crane commissioning records
2. Delivery form

Crane commissioning records

Manufacturer		Contract No.			
Delivery date		Commissioning date			
Capacity t		Span m		Duty group	
Location					
Load test	Load t	Commissioning time min	Deflection mm	Camber without load mm	Inspector
Static load	100%				
	125%				
Dynamic load	110%				
Limit switch performance					
Main hook hoist switch		Aux.hook hoist switch			
Crane traveling switch		Trolley traversing switch			
Problem					
Solution					
Responsible person:			Recorder:		

Crane delivery form

User name:

Location:

Crane capacity:

Crane span length:

Crane model:

Commissioning date:

Crane assembling and commissioning conform to crane design, requirement and quality is approved.

Commissioning party:

Installation company:

Installation company responsible person:

Acceptance Party responsible person:

Acceptance Party:

Acceptance Party:

Precautions:

1. Crane commissioning records should be hold by both Crane assembling company and end user; any of the problems occurred during the crane commissioning should be recorded as original record, no matter whether the problems are solved or not.
2. Crane manufacturer should guarantee the crane smooth performance for 12 months since put into work but no later than 18 months after the crane delivery.
3. Crane performance and maintenance should conform to requirement of instruction manual. User should keep the spare parts and steel structure properly before crane assembling.

Five Lubrication

Lubrication is very important to crane's smooth performance and working life, so the crane operator and maintenance staff should check the lubricating point as per requirement.

1. Crane lubrication point distribution

(1) Shaft of hook pulley sheaves (2) Shaft of fixed pulley sheaves (3) Wire rope

(4) Reducer (5) Bearing house (6) Motor bearing (7) brakes (8) Shaft on grab

2. Lubrication condition and lubricant

Crane lubrication should be regular and change of lubricate oil should be in time. Lubrication device and oil point should be kept clean. Please refer to following form for lubrication time and lubricant.

Lubrication time and lubricant of main parts

No	Item	Specification	Lubrication condition	Lubricant
1	Wire rope	15-30 days	1. Heat the lubricant to 80-100 C. 2. Without heating	Albany grease (GB443-56)
2	Reducer	3 months	Summer	Machine oil N46 (GB443-84) Machine oil N32 (GB443-84)
3	Gear coupling	1 month	Winter (no less than -20C)	synthetic calcium base lubricating grease (sty1409-76)
4	Roller bearing	3-6 months		Ball roller bearing grease (sty1409-76)
5	Slide bearing	As per working condition		Albany grease (GB443-56)
6	Motor			Ball roller bearing grease (st1514-B2)

Remark:

- (1) This form is as per cranes of duty group A5, should lengthen or shorten the lubrication period by considering duty group difference, working area and condition.
- (2) Albany grease should not be used in case it's humid area.
3. Hydraulic brake should have enough hydraulic oil to make sure the brake's good condition.

Six Operation instructions

Safety Technical Regulations

1. Safety technical regulations should be followed during crane operation
 - (1) Crane operator should be trained before operating the cranes
 - (2) Over load lifting is forbidden, wire rope side lifting is forbidden.

-
- (3) Nameplate with capacity, span length, duty group and manufacturer name should be attached to the crane.
 - (4) People are forbidden to stay in the bridge structure during crane operation.
 - (5) Power off during crane inspection and maintenance.
 - (6) Hook should be over human height when the crane is running without load.
 - (7) Load should be at least 0.5m higher than the obstacles on the path of crane running.
 - (8) Don't throw anything from the crane.
 - (9) Load is forbidden to move over human being.
 - (10) It's forbidden to lift human being.
 - (11) Flammable materials is forbidden to put on the crane.
 - (12) Outdoor use crane should not work in case the wind is greater than grade 6.
 - (13) Tools, spare parts should not be put on crane structure in case its falling down.
 - (14) Wire rope should be checked during every shift, detailed inspection every 7-10 days.
 - (15) Safety technical inspection should be done every year.

2. Electrics inspection and safety technical regulations

- (1) Maintenance of electrics should be by those who are familiar with electro circuit.
- (2) The crane should not work in case the shell of bare conductor is incomplete.
- (3) If lighting is needed during the maintenance, use portable lighting.(less than 36V)
- (4) Power off during maintenance.
- (5) Any of the motor, electrics and electrical enclosure that has possibility of electric conduction, should be ground connection.

Crane operator responsibility

- (1) Should be familiar with crane assembling, operation and maintenance.
- (2) Should follow safety technical regulations.
- (3) Following should be done before crane operation:
 - ① Check the power supply
 - ② Do the lubrications as per requirement
- (4) Make sure cabin is closed and all control button at 0 position when power is on.
- (5) Warning horn is on when the crane running.
- (6) The crane should not over load.
- (7) Stop the crane once receive the order no matter who gives the order.
- (8) It's forbidden to use the crane to drag load.
- (9) Either the crane or the trolley should move slowly to limit positions, it's forbidden to hit the stop in order to stop the movements.
- (10)Crane control should be turned on one by one, it's forbidden to stop the movement by turning on reverse control before all mechanism stops completely.
- (11)Rail locker should be at work when crane is not working and no work is around.
- (12)Main switch should turn off and all controls should at 0 positions when power supply is cut or obvious voltage reduction.
- (13)In case the material is not unloaded and the power is off, should warn people not walk under the hook.

-
- (14) After crane stop working, the hook should be lifted to the highest position, and all controls should at 0 positions, cut the main switch, and lock it well.
 - (15) Clean and make daily crane check of all the mechanism, record carefully the fault on the communication book, and inform the related department and operator.

SEVEN Crane Maintenance

To keep crane's normal and safe work, should operate correctly, check regularly, and maintain often. Therefore, should make check of crane mechanism every week, and also check the entire fastener's connection, as well as the check for main parts. The adjustment and maintenance's description is as following:

1. Bridge Structure and Maintenance.

Crane's bridge structure and main metal structure should make complete inspection annually.

- (1) Check all the connect bolts, and there is forbidden to have any loose;
- (2) Check main welding line, and if there is any crack, should eradicate and reweld with good electrode, ensure the weld quality;
- (3) Check main girder's camber. Check the main crane's camber F when there is no load (and travel the trolley through support beam), check the cantilever's camber $F1F2$ upwarp's degree when travel the trolley at the main girder's middle. When $F > 11350L1(L2)$, should make repair, only after the main girder's camber satisfy the requirement, the crane can work.
- (4) Should repair other main mechanism if there is any transformation.
- (5) Crane and trolley's travel rail should be check twice every year, and check rail's firm situation, mutual position, adjust them if there is any difference. Should replace the rail if the rail side's abrasion more than 15% of original rail.

2. Crane and trolley travel mechanism.

- (1) Rail Gnawing: This means that the wheel rim seriously contact with rails, and have large sounds or shake during travel. For example, if there is rail gnawing on same direction, should readjust the wheel's horizontal decline, and let the two driving wheel (or driven wheel)'s decline opposite. If the rail gnawing is opposite during travel, then this may due to motor or brake's asynchronous; if there is rail gnawing on some rails, maybe there is problem of wheel or span. If there is trolley rail gnawing, this normally due to main girder's sink, which arouse main girder's inward bend. If the bend is not very serious, should adjust wheel's gauge; but if the bend is very seriously, should repair the main girder, and do not easily change rail.
- (2) Main driving wheel Slip: If there is wheel slip, should check whether main driven wheel and rail are contact, or should add washer to adjust angle gear box. If the slip is due to grease, should scatter some fine sand to enlarge the friction. Then should adjust the braking torque to forbid sudden brake.

3. Lift Mechanism

- (1) Could be aroused by the following reason:

- ① Brake wheel have grease, and should clean the brake wheel surface with oil refining, and after the brake wheel be dry can continue use;
- ② Brake's main spring force is not enough, should adjust decrement or compressing force according to drawing's requirement ;
- ③ Brake belt have excessive abrasion, when the abrasion is more than 30%, should replace the brake belt;
- ④ Spring have plastic transformation, the small shaft or axle hole's diameter abrasion arrive more than original diameter's 5%, should replace the spring;
- ⑤ Brake shoe's gab are too big, should adjust the gab, and there is abrasion is ok.
- ⑥ Check whether handspike motor's brake capacitive load is reliable.

3. Safe switch's malfunction are due to the inner material clamping stagnation or displacement. When adjust and use should mention the following tips:

- ① The hook safe use should ensure: When hook with load lift, the spreader's highest point and the trolley's related material distance should large than 200mm when cut the electricity.
- ② After change or string the wire rope, should readjust the limit switch;
- ③ Every operator should try the safe limit switch before formally work;
- ④ The operator should not first replace formal operation with safe operation.

4. Wire Rope

(1) Wire rope's check and maintenance: Should regularly check wire rope's fix situation on the end, and the wire rope's broken line and abrasion. If there is any the following situation, should handle as soon as possible: wire rope's diameter become thin, elasticity become small, or other transformation etc. Should keep the wire rope in good lubricant situation, and should remove the dirt first before making lubricating, and cleaning it with kerosene, then heat the grease to more than 80 °C, so that the oil can immerse into wire rope.

(2) Wire rope's replacement: Replace new wire rope should accord with the original model, specification, and the tensile strength should be qualified. When the wire rope is not longer enough, it is forbidden to connect two short wire ropes. When there do not have enough document to clarify the wire rope's quality, should make fracture test as requirement.

(3) Wire Rope's scrap.

- ① Depend on every twiddle's steel wire decide, check table 8

Table 8 Disconnected Number of every wire rope

Wire rope disconnected number and safe data	Wire rope structure			
	Rope6X (19) (GB102-74)RopeX (19)		6X37 (GB1102-74)	
	Entwine	Order Entwine	Entwine	Order Entwine
≤6	12	6	22	11
6-7	14	7	26	13

Note: A broken line number is for thin steel wire, and the thick should equal to 17. Times thin wire rope.

If the B broken line arrive the number in the table, then it is scrap.

② If the wire rope is used to lift casting, red-hot metal, acid solution, explosive, combustible or other harmful goods, the scrap standard should be half of Table 8, including the surface abrasion.

③ If there is rusting or abrasion, should decline the broken line number in Table 8 according table 9. If more than table 9, should scrap the wire rope.

Table 9 Reduction Factor Table

Disconnected No	10	15	20	25	30-40	>40
Reduction Factor%	85	75	70	60	50	0

④ If there is one piece wire rope broke, the wire rope should also be scraped.

5. Bearing

Check the bearing's assembly and lubrication whether they are qualified, and if there is any strange sounds, should make test.

6. Wheel:

Whether there is crack and abrasion, if there is crack or abrasion more than original wheel rim's 50% or original wheel thickness's 15% should change the wheel. When the indentation is 3mm, should reproduce, and ensure that the one crane's wheel diameter deviation should not more than $0.0003D$. (D =Wheel Diameter)

7. Drum and Pulley

(1) Drum

① Check the wire rope's end fix situation monthly.

② If the drum 's crack or abrasion is more than 30% original, the drum is scrap.

(2) Pulley

① Crack;

② Wheel race uneven abrasion arrive 3mm;

③ Due to abrasion make the groove's bottom diameter reduce to wire rope diameter's 50%.

④ Other deflect which can harm wire rope.

8. Reducer

Reducer should not have unmoral sound, if have should check the following: gear surface's abrasion situation and mesh situation, reducer's installation quality or oil lever is qualified.

9. Bearing and direction transmission shaft

Check whether transmission shaft and bearing's are stable, whether connect bolts are loose, and whether it will bounce during work.

10. Brake should be test between the shaft, and the travel brake need be test every 2/3 month, and should confirm whether all the brake mechanism is flexible, whether there is oil leak during the check. When brake, the brake tile need correctly cling to the brake wheel, and the connect surface should large more than 75%. When it open, the gab of brake wheel's side should me same. Check brake torque, and for the lift mechanism, the brake have to effectively stop 1.25 times lift capacity. For the travel mechanism, between the rated brake distance, can ensure brake crane or trolley, the brake distance is determined by work operation. If the brake washer abrasion is more than 30% original of original one, should replace it. If the brake wheel have more than 0.5mm dent or scratch, have to make modification. Should clean the brake wheel's surface with kerosene timely. When there is burnt odor or smoke, should timely adjust the brake wheel's gab, and make the gab is same. All the connection of brake wheel, every week should make the lubrication, so that it can be in good condition, and the usage of brake oil please refer to Table 10.

Table 10 Hydraulic Brake Oil Table

Temperature	Oil Type
45°C~20°C	20# Mechanical Oil
20°C~0°C	10# Transformer Oil
0°C~-15°C	25# Transformer Oil
-15°C~-30°C	Instrument Oil
Less than -30°C	Mixture of Alcohol and Glycerinum

Should check brake electricity regularly , and check hydraulic handspike 's motor and electric circuit.

11. Hook

(1) Hook should not have crack and transformation

(2) The hook should be scrap if there is any situation of followings:

① The dangerous section abrasion arrives original's 10%

② Open degree increase more than 15% than original size

③ The curved transformation more than 10°

④ The risk section or hook's neck have plastic transformation.

(3)Forbid repair weld of hook's deflect

(4)Check the hook, hook nut and hook thread at least 1 time every year, if there is damage or serious abrasion should replace it.

12. Control Screen (Controller)

When use control screen, should mention maintain the positive and negative side, and keep contact's smooth and keep normal pressure.

13. Power Supply Rail(Power Supply Cable)

Should keep the power supply cable surface's clean, and the insulator should be whole, and tightly be fixed on the support beam. If there is fire means bad contact, this may due to power supply rail and cable trolley's loose connection or dirty surface. Should regularly check cable's wrong situation and soft cable, trolley, and drum's right work.

14. Magnet Crane Mechanism:

(1) Magnet power supply cable should simultaneously lift up and down, and the cable itself should keep looseness, and should prevent the cable entwine together with other things during travel.

(2) Should mention whether the magnet resistor and dc control screen's collision are normal.

15. Grab Mechanism

Grab's up and down should control 2 master controller, every gear should mutually alignment, or need try to make adjustment, and the open & close single control open& close master controller.

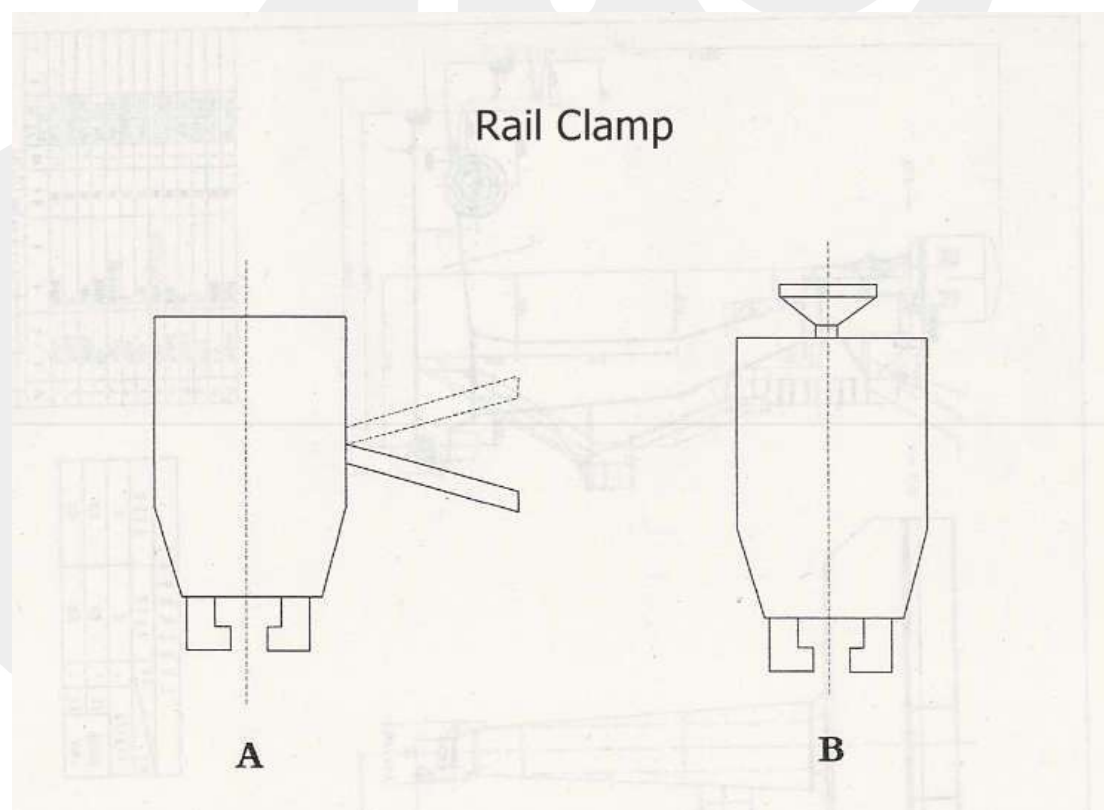

Notes:

1. A type rail clamp: When the controller is on position 1, the clamp will down and connect between rail, when the crane travel along the rail, the clamp can stop the travel.
2. B type rail clamp: When lift the hand wheel up, the clamp will lose, and when down the hand wheel, the clamp will tightly catch the rail, and stop the travel.